



Rapid Change Block Quintus
for workholding systems MC, PC and SCS
3 sizes, with or without zero point clamping system



Description

The rapid change block Quintus has been developed to fix the workholding systems MC, PC and SCS on the machine table, alternatively with or without integrated mechanical STARK zero point clamping system "SPEEDY metec". It serves as elevation base for the workholding system and ensures a good accessibility of the machining tools to the workpiece. The integrated mechanical STARK zero point clamping system "SPEEDY metec" enables a rapid and zero point accurate change of the workholding system. Thus, machining tasks can be prepared externally and can then be carried out without long machine downtimes. Handling is made easier and set-up and production costs are reduced. "SPEEDY metec" is characterised by its simple and sturdy design as well as easy handling. Due to its mechanical functioning no external energy is required. With a few turns, the rapid change block is clamped or unclamped. The rapid change block Quintus is available in 3 sizes, adapted to the sizes of the workholding system.

Rapid change block Quintus 1 for MC 60, PC 80 and SCS 80

Design with STARK zero point clamping system SPEEDY metec: Part no. 9.6153.0101

Insertion force: 12 kN at 60 Nm

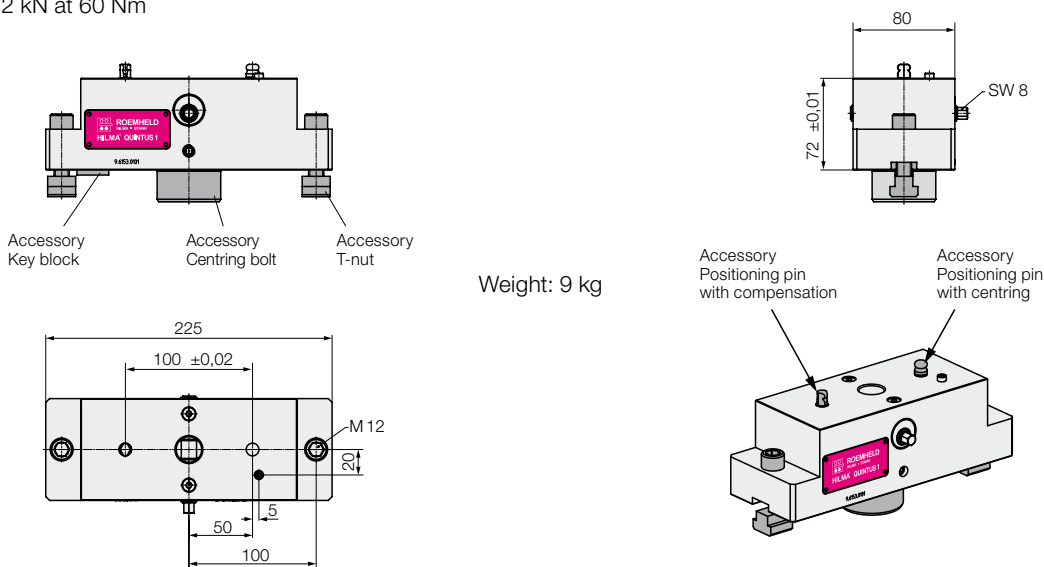

Design without STARK zero point clamping system SPEEDY metec: Part no. 9.6153.0102

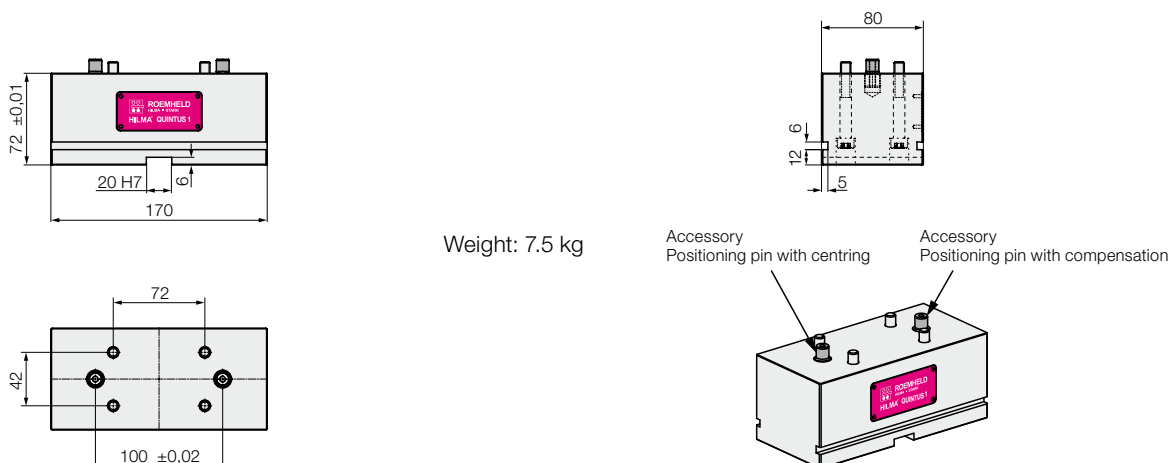

**Rapid change block Quintus 2
for MC 100 and SCS 120**

Rapid change block Quintus 2 for MC 100 and SCS 120

Design with STARK zero point clamping system SPEEDY metec: Part no. 9.6155.0102

Insertion force: 2 x 20 kN at 80 Nm

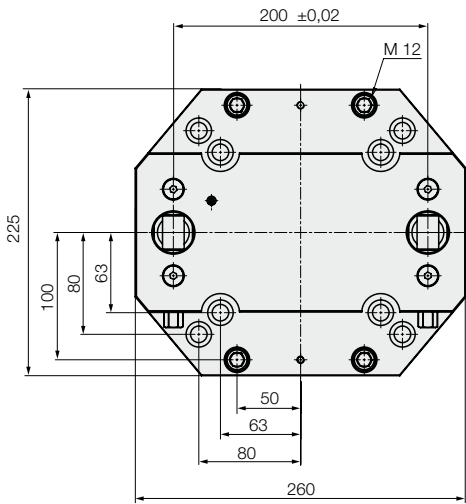
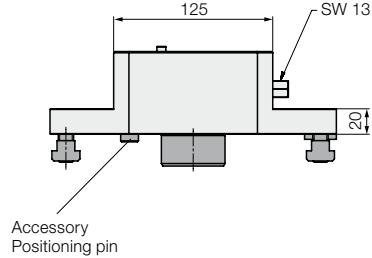
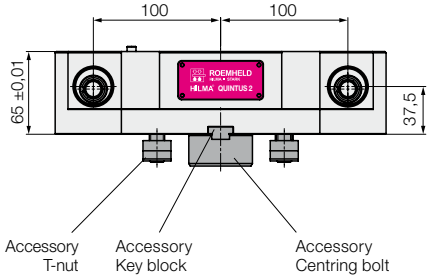

Weight: 19 kg

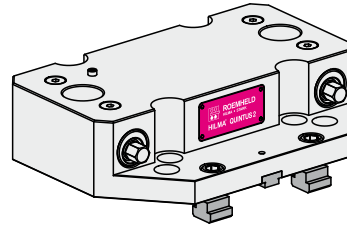

Design without zero point clamping system: Part no. 9.6155.0103

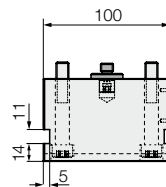
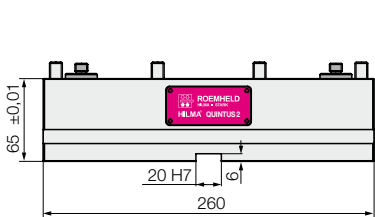

Weight: 13 kg

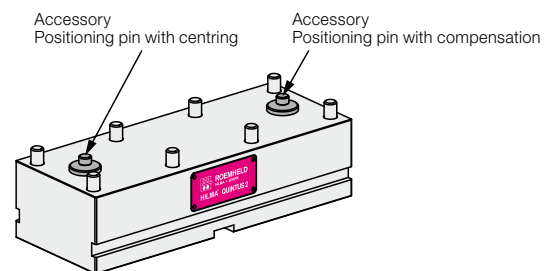
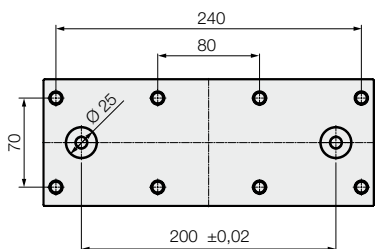

Rapid change block Quintus 3
for MC 125

Rapid change block Quintus 3 for MC 125

Design with STARK zero point clamping system SPEEDY metec: Part no. 9.6156.0102

Insertion force: 3 x 20 kN at 80 Nm

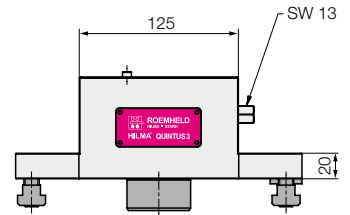
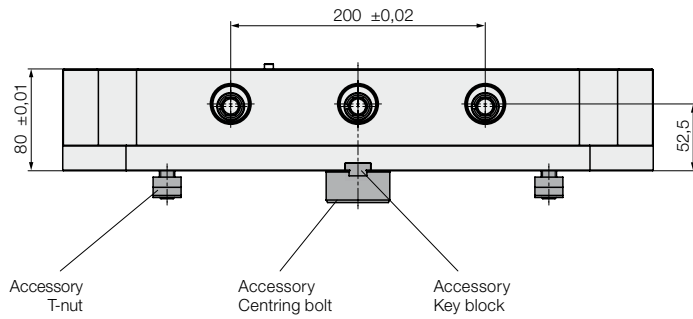

Weight: 42 kg

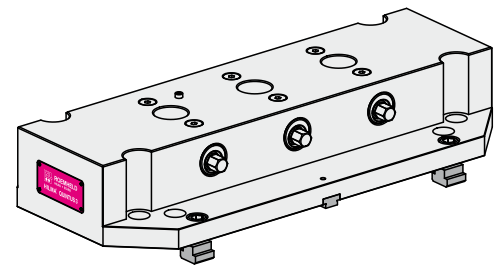
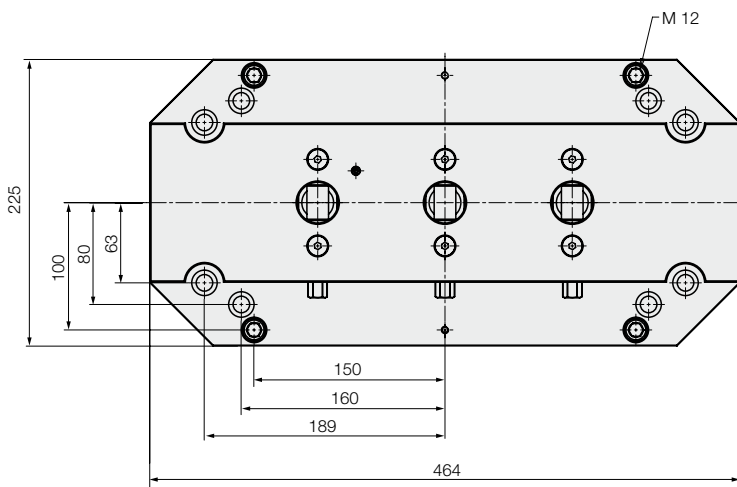

Design without zero point clamping system: Part no. 9.6156.0103

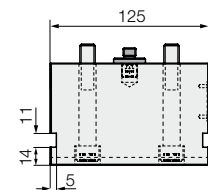
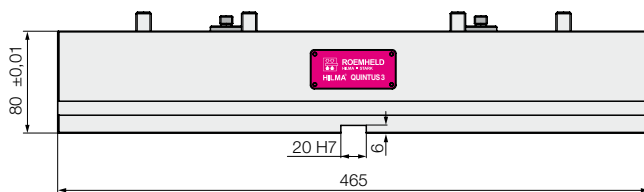

Weight: 35 kg

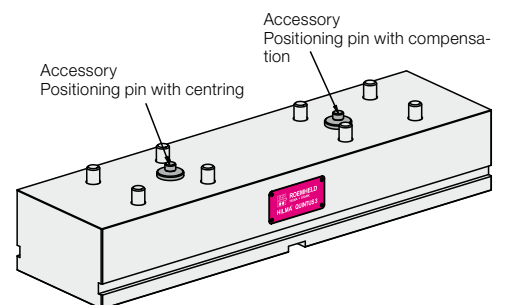
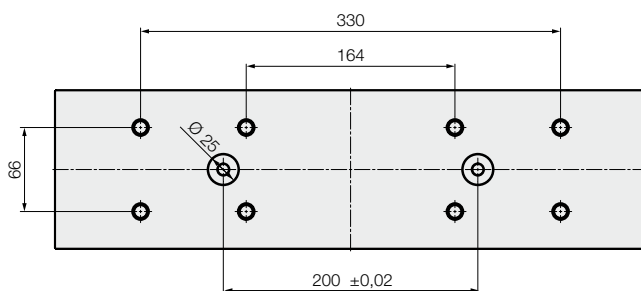

Accessories for mounting, positioning and operation

Mounting and positioning

Centring bolt
for hub centring on machine table



Type Quintus 1/2/3 with and without clamping lock

Part no.	Ø [mm]	L [mm]
9.6153.5001	D30 g6	15/38
9.6153.5002	D32 g6	15/38
9.6153.5003	D50 g6	25/48
9.6153.5009	D50 g6	18/41

Positioning pins
stepped for grid plate and Quintus, set of 2 off



Type	Part no.	Ø [mm]
Quintus 1 9.6153.0102	9.3920.0101	10/12
Quintus 2 9.6155.0102	9.3920.0102	10/14
Quintus 2 9.6155.0103	9.3920.0103	25/12
Quintus 3 9.6156.0103	9.3920.0103	25/12

Clamping claws
Set of 4 off including screws



Type	Part no.	Thread
Quintus 1 9.6153.0102	9.3583.7001	M10
Quintus 1 9.6153.0102	9.3583.7002	M12
Quintus 2 9.6155.0103	9.3585.7001	M12
Quintus 3 9.6156.0103	9.3585.7001	M12

Key block
with screw



Type Quintus 1/2/3 with and without clamping lock

Part no.		Slot [mm]
9.6153.5004	DIN 6322, 1 off	14

T-nut
with screw



Type Quintus 1/2/3 with and without clamping lock

Part no.		Slot [mm]
9.6153.5005	DIN 508, 4 off	14

Operation

Torque wrench
Type Quintus 1/2/3 with clamping lock



Part no.	Torque [Nm]
9.3792.6610	20–120

Socket
for torque wrench



Type	Part no.	SW
Quintus 1 9.6153.0101	1.3124.0104	8
Quintus 2 9.6155.0102	1.3124.0013	13
Quintus 3 9.6156.0102	1.3124.0013	13