



**ROEMHELD**  
HILMA ■ STARK



## **STARK.classic.NG**

Zero point clamping system  
Single acting, hydraulic or pneumatic



**STARK**  
**INNOVATIVE**  
**PROFICIENT**  
**INDIVIDUAL**  
**RELIABLE**

The high-tech company STARK Spannsysteme, founded in 1977, is regarded as a pioneer in the development and manufacture of zero point clamping systems, being the first company on the market to specialise exclusively in this technology for decades.

High quality and precision distinguish what is possibly the broadest product range available on the market in the field of highly productive work-piece clamping.

Production is more efficient and flexible with STARK components, products and systems.



AUTOMOTIVE



AVIATION



MACHINE AND TOOL  
CONSTRUCTION



MEDICINE

**FOCUS ON**  
**INDUSTRIES**  
**& MARKETS.**

Every customer has specific requirements. Our established and extensive industry expertise allows us to offer you the best solutions, services and products for sustainable and efficient use in your market.

# STARK.classic.NG

- lifting:** STARK.classic lifts the pallet upon release
- simple:** easy to clean
- precise:** due to cylindrical fit
- durable:** press-fitted bolts
- versatile:** clamping control, seat check, blow-out, media duct



## STARK

# Spannsysteme

More productivity through:

- maximum flexibility in production
- maximum process reliability
- reduced manufacturing costs thanks to set-up time optimisation

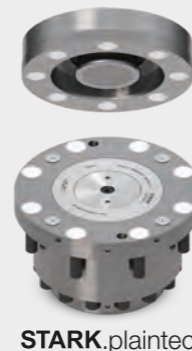
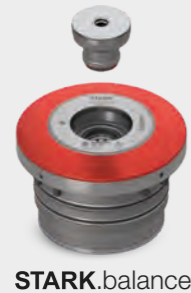

## Table of contents STARK.classic.NG

### INFORMATION

Functions and benefits	6-9
Technical data	10, 19
Tilting moment calculation	11

### CLAMPING ELEMENTS

<b>STARK.classic.NG.1</b>	
STARK.classic.NG.1, Standard	12
STARK.classic.NG.1, Tornado	12
STARK.classic.NG.1, Twister	13
<b>STARK.classic.NG.2</b>	
STARK.classic.NG.2, Standard	14
STARK.classic.NG.2, Tornado	14
STARK.classic.NG.2, Twister	15
<b>STARK.classic.NG.3</b>	
STARK.classic.NG.3, Standard	16
STARK.classic.NG.3, Tornado	16
STARK.classic.NG.3, Twister	17
<b>STARK.classic.NG Pneumatic</b>	18-19
<b>STARK.classic.NG-S</b>	24-25

Element matrix STARK.classic.NG	20-21
Application examples	22-23
Pre-assembly and transportation lock	28
Surface-mounted housing	29

### Functional description

Ways to increase precision	26-27
Clamp control	30
Clamp control valve and visual clamp control	31
Released control	32
Seat check	32
Coolant outlet	34
Integrated media duct	34
Indexing	35

### RETRACTABLE NIPPLE

<b>STARK.classic.NG.1</b>	
STARK.classic.1 retractable nipple with zero point	36
STARK.classic.1 retractable nipple with equaliser	36
STARK.classic.1 retractable nipple with centring	37
<b>STARK.classic.NG.2</b>	
STARK.classic.2 retractable nipple with zero point	38
STARK.classic.2 retractable nipple with equaliser	38
STARK.classic.2 retractable nipple with centring	39
<b>STARK.classic.NG.3</b>	
STARK.classic.3 retractable nipple with zero point	40
STARK.classic.3 retractable nipple with equaliser	40
STARK.classic.3 retractable nipple without centring	41
Equaliser via retractable nipple	42
Retractable nipple with air recess	43
Short retractable nipples without lifting out of the fit	43
Pendulum nipple and floating nipple	44-47
Nipple fastenings	48-49
Spacer and support disc	50-51

### ACCESSORIES

Pressure boosters, pumps, assemblies, DH	52-56
Media ducts	56-63
Pre-centring	64-65
Couplings	66-68
Clamp control valve installation aid	69
Positioning nipple	69
Sliding block	69
Retractable nipple transport protection	70
Sealing plugs	70
Specification dimension tester	70
Ball retainer assembly aid	71
Mechanical insertion force tester	71
O-rings service set	72
Cup springs and O-rings service set	72
Screw cover	72
Hydraulic assembly aid	73
Hand pump	73
Assembly aid	73

► Note NEW order numbers - see info on page 75

List of order numbers 74

## Functions and benefits

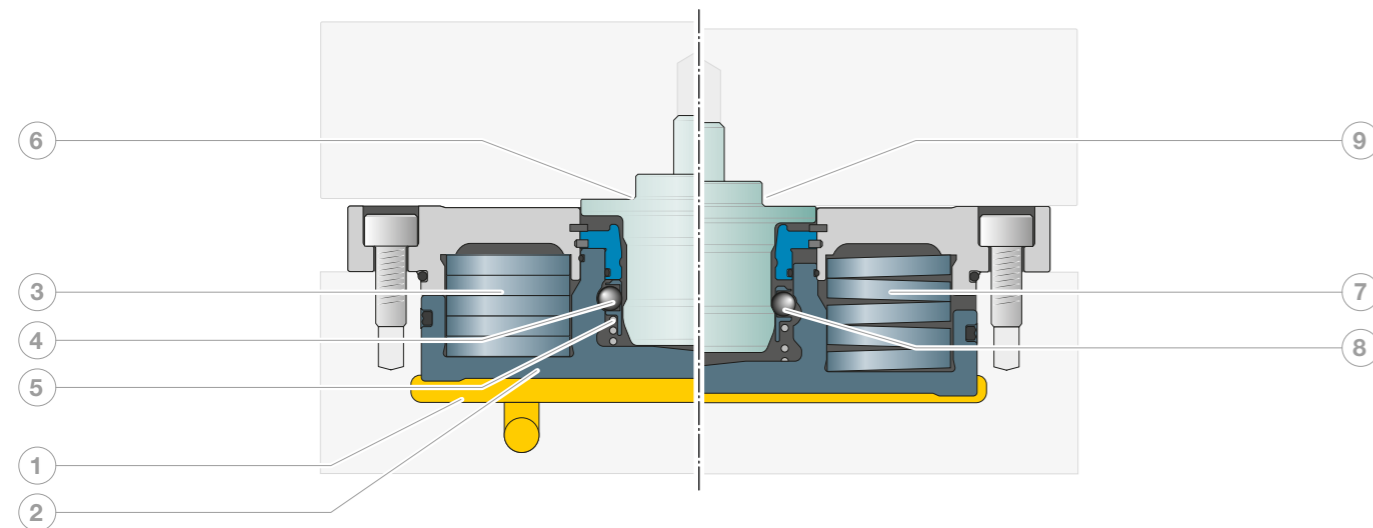
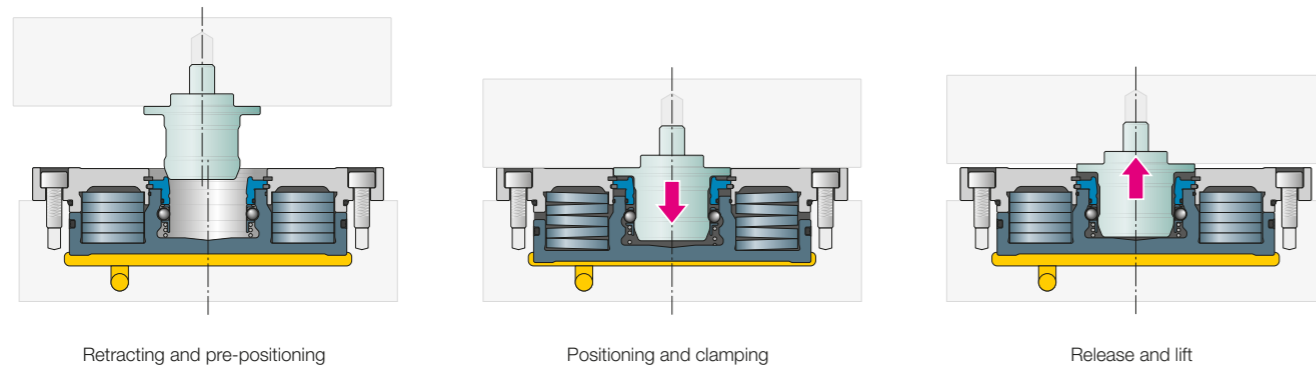

### Hydraulic release

- The piston (2) is subjected to the hydraulic pressure (1) and moves upwards. The spring assembly (3) is compressed.
- The balls (4) in the ball retainer (5) move outwards to the parking position.
- The retractable nipple (6) moves into the fast closing clamp until it rests against the piston crown.
- The retractable nipple (6) is pre-positioned.

### Mechanical clamping

- The hydraulic system is relieved, the oil pressure drops to 0 bar.
- The spring pre-tensioning force is initiated via the piston (2) which moves down. The fit is joined and the retractable nipple (9) is positioned with high precision.
- The balls (8) lie form-fitted between the piston and the retractable nipple in the contour provided.
- The pre-tensioning force of the springs (7) now acts directly and permanently downwards on the retractable nipple.

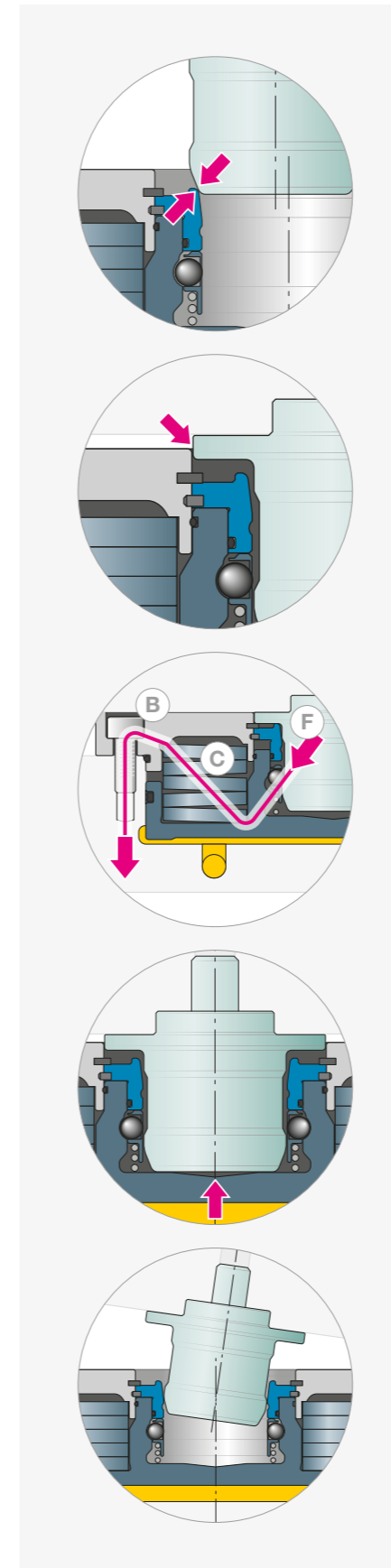

### WEAR-RESISTANT RETRACTING AND PRE-CENTRING

- Due to the special retractable nipple contour, the fitting diameter is not damaged when retracting in the clamping element.
- High alloy tool steel provides wear resistance.

### MATCHED RADII ON THE FITTING DIAMETER

- Matched radii on the clamping element and on the retractable nipple result in exact pre-positioning.
- The fit is joined by retracting the pallet. The operator only has to put down or remove the pallet.
- No chips can be trapped in the cylindrical bore.

### OPTIMAL FORCE DISTRIBUTION – NO BENDING OR LIFTING

- Spring force permanently fixes the retractable nipples in a form-fit and highly precise manner. This has a vibration-damping effect and increases the quality of the surface to be processed as well as the service life of the tools.
- The spring force (F) acts in the immediate vicinity of the fixing screw (B). This means that there is no deflection on the disc (C).

### LIFTING OUT OF THE FIT

When releasing, the retractable nipple is lifted out of the fit in a controlled manner and the operator recognises that the system is released. This makes handling safe and extremely simple.

### INCLINED RETRACTING AND EXTENDING

Changing workpieces, devices or pallets without tilting. Particularly suitable for asymmetrical weight distribution above the pallet with STARK.classic.NG.2 and NG.3.

## Functions and benefits

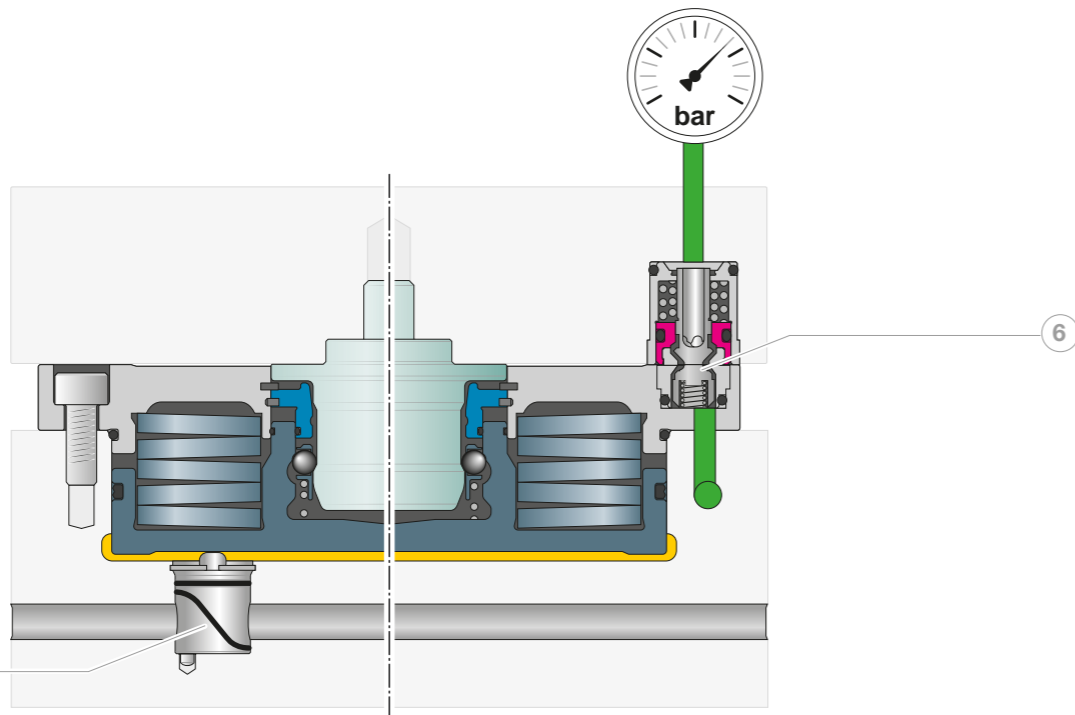
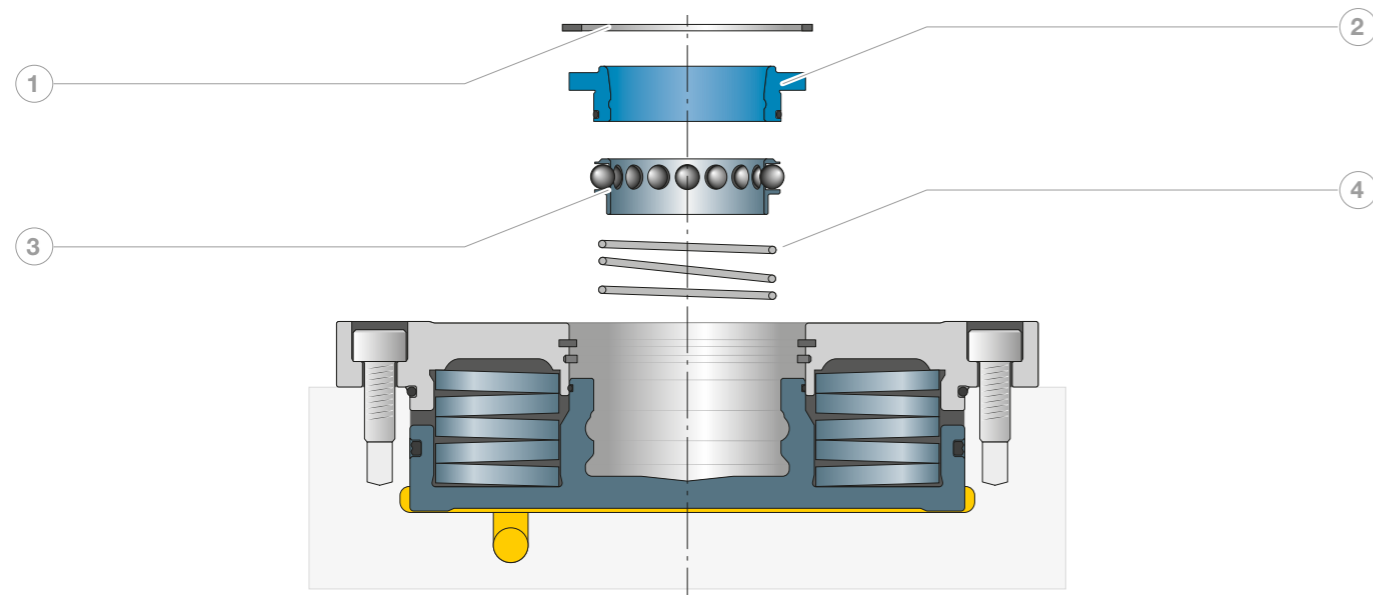

- 1) Lock ring
- 2) Retaining ring
- 3) Ball retainer
- 4) Spring
- 5) Clamp control valve
- 6) Integrated media duct

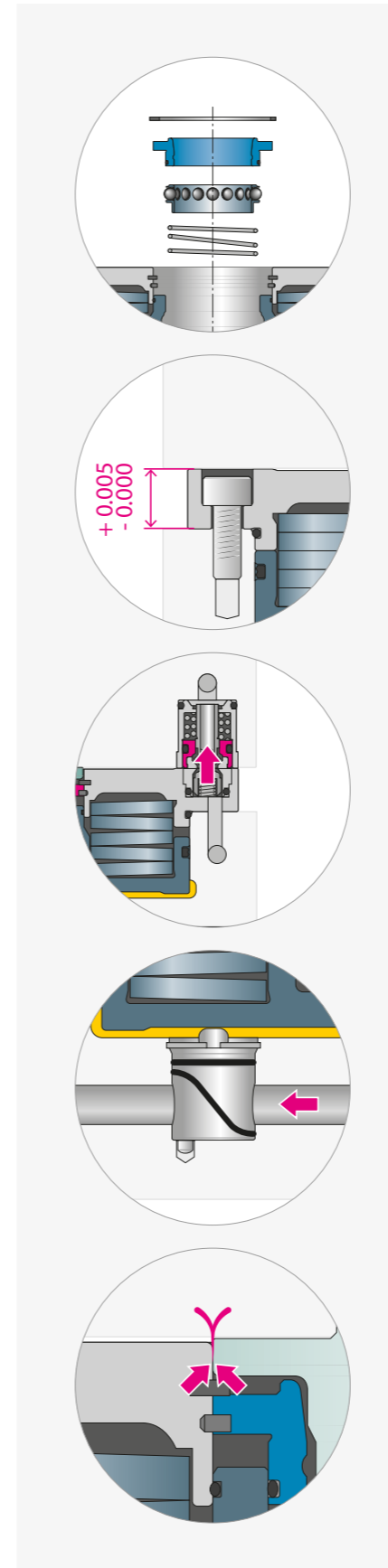

### EASY CLEANING

- In machining production, contamination of the clamping system is unavoidable in the long term. Therefore, an easy cleaning option is very important.
- For the STARK.classic.NG fast closing clamp, the retaining ring (2), ball retainer (3) and spring (4) can be easily removed, cleaned and used again after the lock ring (1) has been removed. This enables easy maintenance and the lowest possible downtimes.
- Easy to exchange due to highly accurate tolerances – no need for set-up or tuning.

### PRECISE SUPPORT

- For special requirements, the Twister design can be supplied with a tolerance of  $2 \mu$  – particularly advantageous for high-precision, matched systems (e.g. clamping element changeover).
- Highest accuracy to reduce tolerance errors.
- The standard tolerance for the disc height of STARK clamping elements is  $5 \mu$ .

### INTEGRATED MEDIA DUCT

- For the passage of media such as oil, air, water, etc., STARK.classic.NG can be equipped with integrated media ducts (6) on request. These are automatically positioned and coupled during clamping.
- This allows, for example, clamping devices mounted on machine pallets to be supplied with energy (hydraulics, pneumatics, etc.). The coupling force is applied by the clamping element. With extremely simple handling, the pallet is positioned, clamped and coupled fully automatically.

### CLAMP CONTROL

- For safety reasons, a clamp control is strongly recommended for all high-speed applications. STARK.classic.NG can be optionally equipped with a mechanical clamp control valve (6) for this purpose.
- The evaluation of the clamp control can be integrated directly into the machine control system or can be displayed by means of a visual clamp control. Existing machines can also be retrofitted with a corresponding hydraulic unit and suitable control system.

### HG - HIGH-PRECISION DUE TO PRESS FIT

- High accuracy due to press fit between clamping element and retractable nipple.
- Used in high precision applications in 5-axis or rotary applications in the centre of the fast closing plate, e.g. turbine engine parts.
- This ensures that the axis of rotation is always precisely in the centre. This high accuracy ("aeronautical accuracy") is achieved by a press fit between the retractable nipple and the clamping element. The use of a press fit is made possible by the active insertion and lifting of the STARK.classic system.

## Technical data

		STARK.classic.NG.1	STARK.classic.NG.2	STARK.classic.NG.3
Maintenance interval	Cycles		40,000	
Insertion force <sup>1</sup>	[N]	8,000	22,000	38,000
Retention force <sup>3</sup>	[N]	25,000	38,000	55,000
Min./max. release pressure	[bar]		40/80	
Lifting force at 50bar / 60bar	[N]	4,900/9,100	13,900/21,700	17,000/31,500
Lifting	[mm]	1.2		1.5
Insertion	[mm]	1.2		1.5
Max. permitted lateral forces (90 degrees to equalising direction)	[N]	7,000	9,000	10,500
Release oil volume	[cm <sup>3</sup> ]	20	40	124
Min. permitted clamping time	[s]		2	
Min. permitted release time	[s]		2	
Radial pre-positioning <sup>3</sup>	[mm]	±3	±2.5	±4.5
Axial pre-positioning <sup>4</sup>	[mm]		-0.3	
Repeat accuracy <sup>5</sup>	[mm]		< 0.005 / < 0.001 *	
System accuracy <sup>6</sup>	[mm]		< 0.01	

- <sup>1</sup> Insertion force: The insertion force (pre-tensioning force of the spring assembly) is the load up to which the zero point is guaranteed. The specified insertion force must not be exceeded.
- <sup>2</sup> Retention force: This is the maximum overload up to which the retractable nipple is still held but the zero point has already been left.
- <sup>3</sup> Radial pre-positioning: The loading device must be compliant for automated loading.
- <sup>4</sup> Axial pre-positioning: Retractable nipple is in contact with the piston crown before the clamping process. A gap of max. 0.3 mm is permissible.
- <sup>5</sup> Repeat accuracy: This indicates the accuracy that refers to the change of the same pallet position-oriented on the same interface (clamping elements, etc.).  
\*Repeat accuracy for high-precision (HG) clamping elements
- <sup>6</sup> System accuracy: This refers to the accuracy resulting from changing several pallets, e.g. on different machines.

## INFO Article designation and functions

The article designation for clamping elements and retractable nipples are compiled according to a function code.

### Example:

STARK.classic.NG.2, Standard  
SE N2 H 220 D139 ST NP DH

SE	STARK installation element
N2	STARK.classic.NG.2
H	Hydraulic element
220	Insertion force 22,000 N
D139	Disc diameter 139 mm
ST	Standard
NP	with zero point
DH	Third-hand function

N1	STARK.classic.NG.1	see page 12-13
N2	STARK.classic.NG.2	see page 14-15
N3	STARK.classic.NG.3	see page 16-17
H	Hydraulic element	see page 12-17
P	Pneumatic element	see page 18-19
ST	Standard	
TW	Twister	
TO	Tornado	
NP	with zero point	
AG	with equaliser	
OZ	without centring	
IN	Indexing	see page 36
KA	Coolant outlet	see page 34
HG	High-precision (∅)	see page 27
2M	2μ (disc)	see page 27
DH	Third hand function	see page 55
MD1	1× media duct	see page 34, 56-63
MD2	2× media duct	see page 34, 56-63
MD3	3× media duct	see page 34, 56-63
MD4	4× media duct	see page 34, 56-63

## Tilting moment calculation example

### INFO

### Tilting moment calculation example

#### Example:

Fast closing clamp plate 4 STARK.classic.NG.2 with spacing 400 x 400 and max. feed force of 10 kN with distance of 1000 mm.

#### Question:

Due to the predominance of roughing work, the system is to be checked for a double safety factor. Is the insertion force, the number of fast closing clamps and the spacing selected adequate?

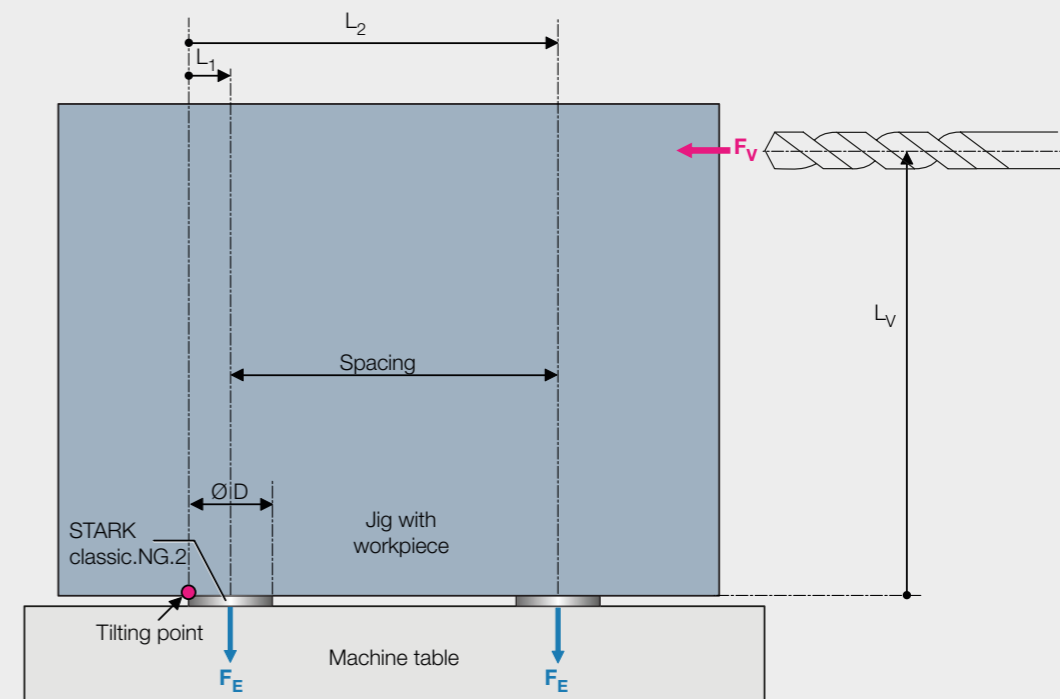

#### Solution:

$$M_E > 2 \times M_V ?$$

$$M_V = F_V \times L_V = 10,000 \text{ N} \times 1.0 \text{ m}$$

$$M_V = 10,000 \text{ Nm}$$

$$M_E = 2 \times (F_E \times L_1) + 2 \times (F_E \times L_2)$$

$$M_E = 2 \times F_E \times (L_1 + L_2)$$

$$L_1 = \emptyset D / 2$$

$$L_2 = \emptyset D / 2 + \text{Spacing}$$

$$L_1 + L_2 = \emptyset D + \text{Spacing}$$

$$L_1 + L_2 = 0.139 \text{ m} + 0.40 \text{ m} = 0.539 \text{ m}$$

$$M_E = 2 \times F_E \times (L_1 + L_2) = 2 \times 22,000 \text{ N} \times 0.539 \text{ m}$$

$$M_E = 23,716 \text{ Nm}$$

$$M_E / M_V > 2 ?$$

$$M_E / M_V = 23,716 \text{ Nm} / 10,000 \text{ Nm}$$

$$M_E / M_V = 2.37 > 2$$

With this design there is a safety factor of 2,37

(Enter all variables in SI units (metres, newtons))

$M_V$  : Moment from feed force

$M_E$  : Moment from insertion force

$F_V$  : Feed force (10,000 N)

$F_E$  : Insertion force (22,000 N)

Spacing = 400 mm = 0.40 m

$\emptyset D$  (bearing ring) : 139 mm = 0.139 m

$L_V$  : 1,000 mm = 1.0 m

## CLAMPING ELEMENTS NG.1

### STARK.classic.NG.1 Standard



Fast closing clamp made of high-quality tool steel

- Installation element 108 mm, standard
- Hydraulic single-acting
- With release and seat check
- Clamp control optional

#### Properties

- Retention force: 25,000 N
- Insertion force: 8,000 N
- Release pressure: min. 40 bar, max. 80 bar
- Element weight: 1.55 kg
- Pre-mounted incl. transport. lock +0.14 kg
- Operating Manual WM-020-332-xx-xx

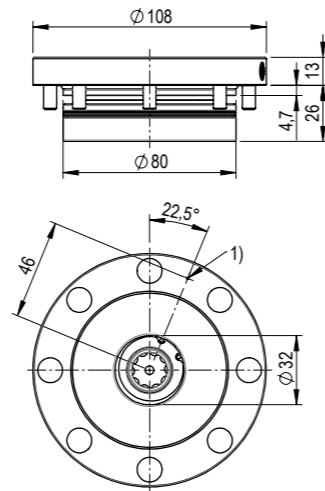

Z\_S804-520\_00

1) Seat check  
- Screw covers M6 S704-231, enclosed separately  
- Cylinder screws with hexagon socket M6 x 16mm S931-139, enclosed separately  
- O-rings Ø5 x 1.5mm S833-051, enclosed separately

Order number	Article designation	Function	Repeat accuracy	Data Sheet
S804-520	SE N1 H 080 D108 ST NP DH	Standard, third-hand function <sup>1)</sup>	< 0,005 mm	D160, D032, D072
S804-521	SE N1 H 080 D108 ST NP HG	Standard, high-precision <sup>2)</sup>	< 0,001 mm	D160, D032, D072
S804-525	SE N1 H 080 D108 ST NP MD1	Standard, 1x media duct <sup>3)</sup>	< 0,005 mm	D160, D032, D072, D021
S804-526	SE N1 H 080 D108 ST NP MD2	Standard, 2x media duct <sup>3)</sup>	< 0,005 mm	D160, D032, D072, D021
S804-527	SE N1 H 080 D108 ST NP MD3	Standard, 3x media duct <sup>3)</sup>	< 0,005 mm	D160, D032, D072, D021
S804-528	SE N1 H 080 D108 ST NP MD4	Standard, 4x media duct <sup>3)</sup>	< 0,005 mm	D160, D032, D072, D021

- ▶ <sup>1)</sup> Third-hand function (DH) - see page 55
- ▶ <sup>2)</sup> High-precision (HG) functional description - see page 27
- ▶ <sup>3)</sup> Media duct functional description - see page 34
- ▶ Element overview with additional functions - see Element Matrix, page 20

### STARK.classic.NG.1, Twister



Fast closing clamp made of high-quality tool steel

- Installation element Ø108 mm, Twister with nozzles, blow-off via 4 support islands
- Hydraulic single-acting
- With release and seat check
- Clamp control optional

#### Properties

- Retention force: 25,000 N
- Insertion force: 8,000 N
- Release pressure: min. 40 bar, max. 80 bar
- Element weight: 1.55 kg
- Pre-mounted incl. transport. lock +0.14 kg
- Operating Manual WM-020-332-xx-xx

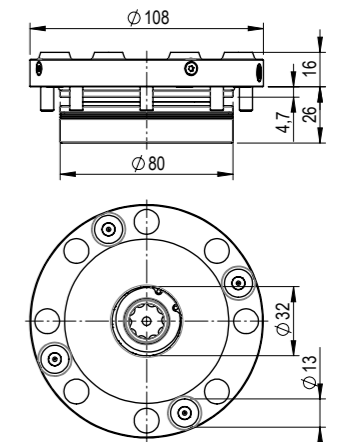

Z\_S804-535\_00

- Screw covers M6 S704-231, enclosed separately  
- Cylinder screws with hexagon socket M6 x 16mm S931-139, enclosed separately  
- O-rings Ø5 x 1.5mm S833-051, enclosed separately

Order number	Article designation	Function	Repeat accuracy	Data Sheet
S804-535	SE N1 H 080 D108 TW NP DH	Twister, third-hand function <sup>1)</sup>	< 0,005 mm	D179, D072
S804-536	SE N1 H 080 D108 TW NP HG	Twister, high-precision <sup>2)</sup>	< 0,001 mm	D179, D072
S804-533	SE N1 H 080 D108 TW NP 2M DH	Twister, 2µ <sup>3)</sup> , third-hand function <sup>1)</sup>	< 0,005 mm	D179, D072, D189
S804-534	SE N1 H 080 D108 TW NP HG 2M	Twister, high-precision <sup>2)</sup> , 2µ <sup>3)</sup>	< 0,001 mm	D179, D072, D189

- ▶ <sup>1)</sup> Third-hand function (DH) - see page 55
- ▶ <sup>2)</sup> High-precision (HG) functional description - see page 27
- ▶ <sup>3)</sup> 2µ functional description, see page 27
- ▶ Element overview with additional functions - see Element Matrix, page 20

### STARK.classic.NG.1, Tornado



Fast closing clamp made of high-quality tool steel

- Installation element Ø108 mm, Tornado with nozzles, blow-off via 4 support islands
- Hydraulic single-acting
- With release and seat check
- Clamp control optional

#### Properties

- Retention force: 25,000 N
- Insertion force: 8,000 N
- Release pressure: min. 40 bar, max. 80 bar
- Element weight: 1,55 kg
- Pre-mounted incl. transport. lock +0.14 kg
- Operating Manual WM-020-332-xx-xx

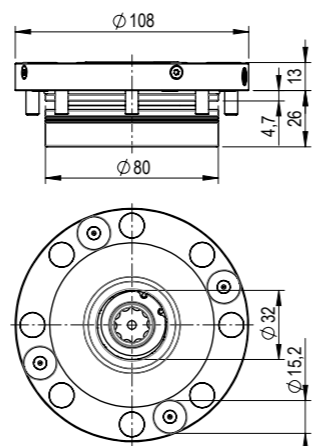

Z\_S804-530\_00

- Screw covers M6 S704-231, enclosed separately  
- Cylinder screws with hexagon socket M6 x 16mm S931-139, enclosed separately  
- O-rings Ø5 x 1.5mm S833-051, enclosed separately

Order number	Article designation	Function	Repeat accuracy	Data Sheet
S804-530	SE N1 H 080 D108 TO NP DH	Tornado, third-hand function <sup>1)</sup>	< 0,005 mm	D179, D072
S804-531	SE N1 H 080 D108 TO NP HG	Tornado, high-precision <sup>2)</sup>	< 0,001 mm	D179, D072

- ▶ <sup>1)</sup> Third-hand function (DH) - see page 55
- ▶ <sup>2)</sup> High-precision (HG) functional description - see page 27
- ▶ Element overview with additional functions - see Element Matrix, page 20

## CLAMPING ELEMENTS NG.2

### STARK.classic.NG.2 Standard



Fast closing clamp made of high-quality tool steel

- Installation element Ø 139mm, standard
- Hydraulic single-acting
- With release and seat check
- Clamp control optional

#### Properties

- Retention force: 38,000N
- Insertion force: 22,000N
- Release pressure: min. 40 bar, max. 80 bar
- Element weight: 2.5kg
- Pre-mounted incl. transport. lock +0.33kg
- Operating Manual WM-020-332-xx-xx

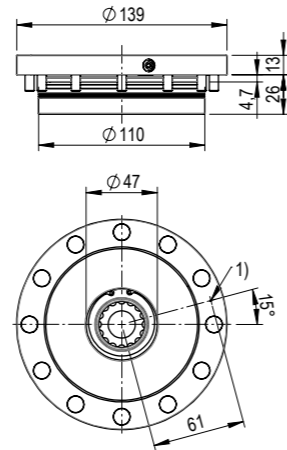

Z\_S804-538\_00

1) Seat check  
- Plastic covers M6 S999-408 enclosed separately  
- Cylinder screw with hexagon socket M6 x 16mm S931-138, enclosed separately  
- O-rings Ø 17 x 1.5mm S833-043, enclosed separately  
- O-ring Ø 6 x 1.5mm S833-051, enclosed separately

Order number	Article designation	Function	Repeat accuracy	Data Sheet
S804-538	SE N2 H 220 D139 ST NP DH	Standard, third-hand function <sup>1)</sup>	< 0.005 mm	D134, D032, D072
S804-538-02	SE N2 H 220 D139 ST NP HG	Standard, high-precision <sup>2)</sup>	< 0.001 mm	D134, D032, D072
S804-545	SE N2 H 220 D139 ST NP MD1	Standard, 1x media duct <sup>3)</sup>	< 0.005 mm	D134, D032, D072, D021
S804-546	SE N2 H 220 D139 ST NP MD2	Standard, 2x media duct <sup>3)</sup>	< 0.005 mm	D134, D032, D072, D021
S804-547	SE N2 H 220 D139 ST NP MD3	Standard, 3x media duct <sup>3)</sup>	< 0.005 mm	D134, D032, D072, D021
S804-548	SE N2 H 220 D139 ST NP MD4	Standard, 4x media duct <sup>3)</sup>	< 0.005 mm	D134, D032, D072, D021

- ▶ <sup>1)</sup> Third-hand function (DH) - see page 55
- ▶ <sup>2)</sup> High-precision (HG) functional description - see page 27
- ▶ <sup>3)</sup> Media duct functional description - see page 34
- ▶ Element overview with additional functions - see Element Matrix, page 20

### STARK.classic.NG.2, Twister



Fast closing clamp made of high-quality tool steel

- Installation element Ø 139mm, Twister with nozzles, blow-off via 4 support islands
- Hydraulic single-acting
- With release and seat check
- Clamp control optional

#### Properties

- Retention force: 38,000N
- Insertion force: 22,000N
- Release pressure: min. 40 bar, max. 80 bar
- Element weight: 2.5kg
- Pre-mounted incl. transport. lock +0.33kg
- Operating Manual WM-020-332-xx-xx

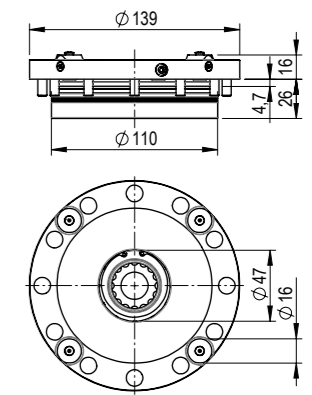

Z\_S804-540-02\_00

1) Seat check  
- Plastic covers M6 S999-408 enclosed separately  
- Cylinder screw with hexagon socket M6 x 16mm S931-138, enclosed separately  
- O-rings Ø 17 x 1.5mm S833-043, enclosed separately  
- O-ring Ø 6 x 1.5mm S833-051, enclosed separately

Order number	Article designation	Function	Repeat accuracy	Data Sheet
S804-540-02	SE N2 H 220 D139 TW NP DH	Twister, third-hand function <sup>1)</sup>	< 0.005 mm	D115, D072
S804-540-01	SE N2 H 220 D139 TW NP HG	Twister, high-precision <sup>2)</sup>	< 0.001 mm	D115, D072
S804-540-12	SE N2 H 220 D139 TW NP 2M DH	Twister, 2µ <sup>3)</sup> , third-hand function <sup>1)</sup>	< 0.005 mm	D115, D117, D072
S804-540-11	SE N2 H 220 D139 TW NP HG 2M	Twister, high-precision <sup>2)</sup> , 2µ <sup>3)</sup>	< 0.001 mm	D115, D117, D072

- ▶ <sup>1)</sup> Third-hand function (DH) - see page 55
- ▶ <sup>2)</sup> High-precision (HG) functional description - see page 27
- ▶ <sup>3)</sup> 2µ functional description, see page 27
- ▶ Element overview with additional functions - see Element Matrix, page 20

### STARK.classic.NG.2, Tornado



Fast closing clamp made of high-quality tool steel

- Installation element Ø 139mm, Tornado with nozzles, blow-off via 4 support islands
- Hydraulic single-acting
- With release and seat check
- Clamp control optional

#### Properties

- Retention force: 38,000N
- Insertion force: 22,000N
- Release pressure: min. 40 bar, max. 80 bar
- Element weight: 2.5kg
- Pre-mounted incl. transport. lock +0.33kg
- Operating Manual WM-020-332-xx-xx

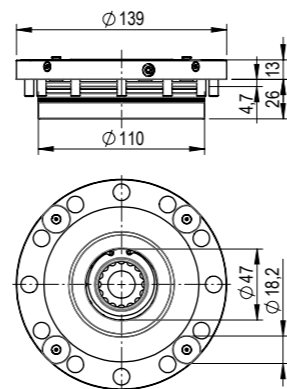

Z\_S806-024\_00

1) Seat check  
- Plastic covers M6 S999-408 enclosed separately  
- Cylinder screw with hexagon socket M6 x 16mm S931-138, enclosed separately  
- O-rings Ø 17 x 1.5mm S833-043, enclosed separately  
- O-ring Ø 6 x 1.5mm S833-051, enclosed separately

Order number	Article designation	Function	Repeat accuracy	Data Sheet
S806-024	SE N2 H 220 D139 TO NP DH	Tornado, third-hand function <sup>1)</sup>	< 0.005 mm	D115, D072
S806-025	SE N2 H 220 D139 TO NP HG	Tornado, high-precision <sup>2)</sup>	< 0.001 mm	D115, D072

- ▶ <sup>1)</sup> Third-hand function (DH) - see page 55
- ▶ <sup>2)</sup> High-precision (HG) functional description - see page 27
- ▶ Element overview with additional functions - see Element Matrix, page 20



## CLAMPING ELEMENTS NG.3

### STARK.classic.NG.3 Standard



Fast closing clamp made of high-quality tool steel

- Installation element Ø 190mm, standard
- Hydraulic single-acting
- With release and seat check
- Clamp control optional

#### Properties

- Retention force: 55,000N
- Insertion force: 38,000N
- Release pressure: min. 40 bar, max. 80 bar
- Element weight: 7.6kg
- Pre-mounted incl. transport. lock +0.72kg
- Operating Manual WM-020-332-xx-xx

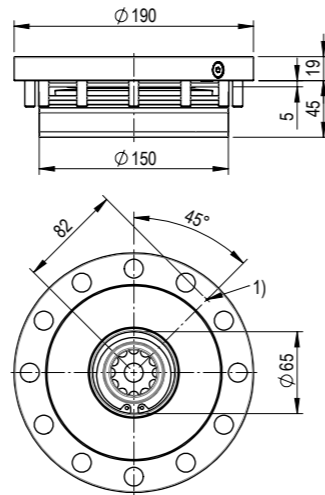

Z\_S807-212\_00

1) Seat check  
- Plastic covers M8 S999-365 enclosed separately  
- Cylinder screws with hexagon socket M8 x 30mm S931-284, enclosed separately  
- O-rings Ø 17 x 1.5mm S933-043, enclosed separately

Order number	Article designation	Function	Repeat accuracy	Data Sheet
S807-212	SE N3 H 380 D190 ST NP DH	Standard, third-hand function <sup>1)</sup>	< 0.005 mm	D106, D032, D072
S807-212-01	SE N3 H 380 D190 ST NP HG	Standard, high-precision <sup>2)</sup>	< 0.001 mm	D106, D032, D072
S807-214	SE N3 H 380 D190 ST NP MD1	Standard, 1x media duct <sup>3)</sup>	< 0.005 mm	D106, D032, D072, D021
S807-215	SE N3 H 380 D190 ST NP MD2	Standard, 2x media duct <sup>3)</sup>	< 0.005 mm	D106, D032, D072, D021
S807-216	SE N3 H 380 D190 ST NP MD3	Standard, 3x media duct <sup>3)</sup>	< 0.005 mm	D106, D032, D072, D021
S807-217	SE N3 H 380 D190 ST NP MD4	Standard, 4x media duct <sup>3)</sup>	< 0.005 mm	D106, D032, D072, D021

- ▶ <sup>1)</sup> Third-hand function (DH) - see page 55
- ▶ <sup>2)</sup> High-precision (HG) functional description - see page 27
- ▶ <sup>3)</sup> Media duct functional description - see page 34
- ▶ Element overview with additional functions - see Element Matrix, page 20

### STARK.classic.NG.3, Twister



Fast closing clamp made of high-quality tool steel

- Installation element Ø 190mm, Twister with nozzles, blow-off via 4 support islands
- Hydraulic single-acting
- With release and seat check
- Clamp control optional

#### Properties

- Retention force: 55,000N
- Insertion force: 38,000N
- Release pressure: min. 40 bar, max. 80 bar
- Element weight: 7.6kg
- Pre-mounted incl. transport. lock +0.72kg
- Operating Manual WM-020-332-xx-xx

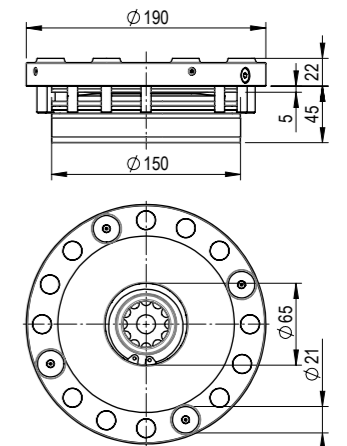

Z\_S804-580-02\_00

1) Seat check  
- Plastic covers M8 S999-365 enclosed separately  
- Cylinder screws with hexagon socket M8 x 30mm S931-284, enclosed separately  
- O-rings Ø 17 x 1.5mm S933-043, enclosed separately

Order number	Article designation	Function	Repeat accuracy	Data Sheet
S804-580-02	SE N3 H 380 D190 TW NP DH	Twister, third-hand function <sup>1)</sup>	< 0.005 mm	D105, D072
S804-580-01	SE N3 H 380 D190 TW NP HG	Twister, high-precision <sup>2)</sup>	< 0.001 mm	D105, D072

- ▶ <sup>1)</sup> Third-hand function (DH) - see page 55
- ▶ <sup>2)</sup> High-precision (HG) functional description - see page 27
- ▶ Element overview with additional functions - see Element Matrix, page 20

### STARK.classic.NG.3, Tornado



Fast closing clamp made of high-quality tool steel

- Installation element Ø 190mm, Tornado with nozzles, blow-off via 4 support islands
- Hydraulic single-acting
- With release and seat check
- Clamp control optional

#### Properties

- Retention force: 55,000N
- Insertion force: 38,000N
- Release pressure: min. 40 bar, max. 80 bar
- Element weight: 7.6kg
- Pre-mounted incl. transport. lock +0.72kg
- Operating Manual WM-020-332-xx-xx

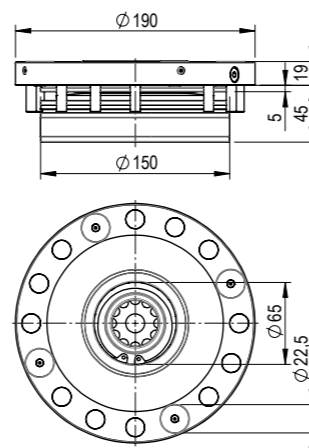

Z\_S804-575\_00

1) Seat check  
- Plastic covers M8 S999-365 enclosed separately  
- Cylinder screws with hexagon socket M8 x 30mm S931-284, enclosed separately  
- O-rings Ø 17 x 1.5mm S933-043, enclosed separately

Order number	Article designation	Function	Repeat accuracy	Data Sheet
S804-575	SE N3 H 380 D190 TO NP DH	Tornado, third-hand function <sup>1)</sup>	< 0.005 mm	D105, D072
S804-576	SE N3 H 380 D190 TO NP HG	Tornado, high-precision <sup>2)</sup>	< 0.001 mm	D105, D072

- ▶ <sup>1)</sup> Third-hand function (DH) - see page 55
- ▶ <sup>2)</sup> High-precision (HG) functional description - see page 27
- ▶ Element overview with additional functions - see Element Matrix, page 20

## STARK.classic.NG PNEUMATIC

The pneumatic versions of the STARK.classic.NG product family are a useful addition to the hydraulic-releasing clamping elements. Particularly suitable for applications with low machining forces such as measuring machines, assembly applications or cleaning systems.

For example, a device that has been clamped for machining with hydraulic-releasing clamping elements can be clamped easily and quickly for intermediate measurements or assembly work with pneumatic-releasing clamping elements.

### AREAS OF APPLICATION

- Applications with low machining forces
- Measuring machines
- Assembly applications
- Cleaning systems

### SPECIAL FEATURES

Detailed information on the pneumatic versions of the STARK.classic.NG product family can be found in the hydraulic-releasing elements. For pneumatic-releasing clamping elements with media ducts, the calculation of the coupling force must be taken into special consideration (see chapter Media ducts).



## STARK.classic.NG.1 P

Order number	Article designation	Function
S804-520-P	SE N1 P 008 D108 ST NP	Standard
S804-522-P	SE N1 P 008 D108 ST NP IN	Standard with indexing
S804-535-P	SE N1 P 008 D108 TW NP	Twister
S804-530-P	SE N1 P 008 D108 TO NP	Tornado

## STARK.classic.NG.2 P

Order number	Article designation	Function
S804-538-P	SE N2 P 025 D139 ST NP	Standard
S804-539-P	SE N2 P 025 D139 ST NP IN	Standard with indexing
S804-540-02-P	SE N2 P 025 D139 TW NP	Twister
S806-024-P	SE N2 P 025 D139 TO NP	Tornado

## STARK.classic.NG.3 P

Order number	Article designation	Function
S807-212-P	SE N3 P 032 D190 ST NP	Standard
S807-213-P	SE N3 P 032 D190 ST NP IN	Standard with indexing
S804-580-02-P	SE N3 P 032 D190 TW NP	Twister
S804-575-P	SE N3 P 032 D190 TO NP	Tornado

## Technical data STARK.classic.NG Pneumatic

		STARK.classic.NG.1 P	STARK.classic.NG.2 P	STARK.classic.NG.3 P
Maintenance interval	Cycles		100,000	
Insertion force <sup>1</sup>	[N]	800	2,500	3,200
Insertion force with booster at 5 bar <sup>2</sup>	[N]	2,800	6,500	10,000
Retention force <sup>3</sup>	[N]	25,000	38,000	55,000
Min. / max. release pressure	[bar]		5 / 10	
Lifting	[mm]	1.2		1.5
Insertion	[mm]		1.2	
Min. permitted clamping time	[s]		2	
Min. permitted release time	[s]		2	
Radial pre-positioning <sup>4</sup>	[mm]	±3	±2.5	±4.5
Axial pre-positioning <sup>5</sup>	[mm]		-0.3	
Repeat accuracy <sup>6</sup>	[mm]		< 0.005	
System accuracy <sup>7</sup>	[mm]		< 0.01	
Weight	[kg]	1.4	2.05	7.6

<sup>1</sup> Insertion force:

The insertion force (pre-tensioning force of the spring assembly) is the load up to which the zero point is guaranteed. The specified insertion force must not be exceeded.

<sup>2</sup> Insertion force with booster

The insertion force can be additionally increased with 5 bar clamping pressure.

<sup>3</sup> Retention force:

This is the maximum overload up to which the retractable nipple is still held but the zero point has already been left.

<sup>4</sup> Radial pre-positioning:

The loading device must be compliant for automated loading.

<sup>5</sup> Axial pre-positioning:

Retractable nipple is in contact with the piston crown before the clamping process. A gap of max. 0.3mm is permissible.

<sup>6</sup> Repeat accuracy:

This usually indicates the accuracy that refers to the change of the same pallet position-oriented on the same interface (clamping elements, etc.).

<sup>7</sup> System accuracy:

This refers to the accuracy resulting from changing several pallets, e.g. on different machines.

## Element matrix STARK.classic.NG

STARK.classic.NG clamping elements are clamped with spring force and released hydraulically (H) or pneumatically (P). Both hydraulic-releasing (H) and pneumatic-releasing (P) clamping elements are designed with zero point (NP). A third-hand function (DH) is possible with hydraulic-releasing clamping elements (H). STARK.classic.NG clamping elements are also available with indexing (IN) and/or coolant outlet (KA).

Standard elements		Additional functions		
STARK.classic.NG.1		IN Indexing	KA Coolant outlet	IN KA Indexing Coolant outlet
<b>Hydraulic-releasing elements</b>		Order numbers		
STARK.classic.NG.1 ST DH	S804-520	S804-522	S804-634	S804-645
STARK.classic.NG.1 ST HG	S804-521	✘	✘	✘
STARK.classic.NG.1 ST MD1	S804-525	S804-523	S804-635	S804-646
STARK.classic.NG.1 ST MD2	S804-526	S804-524	S804-636	S804-647
STARK.classic.NG.1 ST MD3	S804-527	S804-529	S804-637	S804-648
STARK.classic.NG.1 ST MD4	S804-528	S804-532	S804-638	S804-649
STARK.classic.NG.1 TW DH	S804-535	✘	S804-639	✘
STARK.classic.NG.1 TW HG	S804-536	✘	S804-640	✘
STARK.classic.NG.1 TW 2M DH	S804-533	✘	S804-641	✘
STARK.classic.NG.1 TW HG 2M	S804-534	✘	S804-642	✘
STARK.classic.NG.1 TO DH	S804-530	✘	S804-643	✘
STARK.classic.NG.1 TO HG	S804-531	✘	S804-644	✘
<b>Pneumatic-releasing elements</b>				
STARK.classic.NG.1-P ST	S804-520-P	S804-522-P	S804-634-P	S804-645-P
STARK.classic.NG.1-P TW	S804-535-P	✘	✘	✘
STARK.classic.NG.1-P TW 2M	S804-533-P	✘	✘	✘
STARK.classic.NG.1 P TO	S804-530-P	✘	✘	✘

✘ Function not available  
▶ Article designation code - see page 10

Standard elements		Additional functions		
STARK.classic.NG.2		IN Indexing	KA Coolant outlet	IN KA Indexing Coolant outlet
<b>Hydraulic-releasing elements</b>		Order numbers		
STARK.classic.NG.2 ST DH	S804-538	S804-539	S804-538-03	S804-561
STARK.classic.NG.2 ST HG	S804-538-02	✘	✘	✘
STARK.classic.NG.2 ST MD1	S804-545	S804-549	S804-553	S804-562
STARK.classic.NG.2 ST MD2	S804-546	S804-550	S804-554	S804-563
STARK.classic.NG.2 ST MD3	S804-547	S804-551	S804-555	S804-564
STARK.classic.NG.2 ST MD4	S804-548	S804-552	S804-556	S804-565
STARK.classic.NG.2 TW DH	S804-540-02	✘	S804-557	✘
STARK.classic.NG.2 TW HG	S804-540-01	✘	S804-558	✘
STARK.classic.NG.2 TW 2M DH	S804-540-12	✘	S804-559	✘
STARK.classic.NG.2 TW HG 2M	S804-540-11	✘	S804-560	✘
STARK.classic.NG.2 TO DH	S806-024	✘	S806-026	✘
STARK.classic.NG.2 TO HG	S806-025	✘	S806-027	✘
<b>Pneumatic-releasing elements</b>				
STARK.classic.NG.2-P ST	S804-538-P	S804-539-P	S804-538-03-P	S804-561-P
STARK.classic.NG.2-P TW	S804-540-02-P	✘	✘	✘
STARK.classic.NG.2-P TW 2M	S804-540-12-P	✘	✘	✘
STARK.classic.NG.2-P TO	S806-024-P	✘	✘	✘
Standard elements		Additional functions		
STARK.classic.NG.3		IN Indexing	KA Coolant outlet	IN KA Indexing Coolant outlet
<b>Hydraulic-releasing elements</b>		Order numbers		
STARK.classic.NG.3 ST DH	S807-212	S807-213	S807-222	S807-227
STARK.classic.NG.3 ST HG	S807-212-01	✘	✘	✘
STARK.classic.NG.3 ST MD1	S807-214	S807-218	S807-223	S807-228
STARK.classic.NG.3 ST MD2	S807-215	S807-219	S807-224	S807-229
STARK.classic.NG.3 ST MD3	S807-216	S807-220	S807-225	S807-230
STARK.classic.NG.3 ST MD4	S807-217	S807-221	S807-226	S807-231
STARK.classic.NG.3 TW DH	S804-580-02	✘	S804-583	✘
STARK.classic.NG.3 TW HG	S804-580-01	✘	S804-584	✘
STARK.classic.NG.3 TO DH	S804-575	✘	S804-577	✘
STARK.classic.NG.3 TO HG	S804-576	✘	S804-578	✘
<b>Pneumatic-releasing elements</b>				
STARK.classic.NG.3-P ST	S807-212-P	S807-213-P	S807-222-P	S807-227-P
STARK.classic.NG.3-P TW	S804-580-02-P	✘	✘	✘
STARK.classic.NG.3-P TO	S804-575-P	✘	✘	✘

## Application examples for STARK fast closing plate with HILMA vice

	<ul style="list-style-type: none"> <li>■ Fast closing plate with 4 zero point clamping elements STARK.classic.NG.2</li> <li>■ Vice HILMA NC 125             <ul style="list-style-type: none"> <li>■ Mechanically operated</li> <li>■ Clamping force display</li> </ul> </li> </ul>
	<ul style="list-style-type: none"> <li>■ 2x pallet</li> <li>■ Vice HILMA MC-P 100 ZH</li> <li>■ Hydraulically operated</li> <li>■ Media duct</li> </ul>
	<ul style="list-style-type: none"> <li>■ 2x pallet</li> <li>■ Vice HILMA MC-P 100 FM</li> <li>■ Mechanically operated</li> </ul>

## Application example - Milling machine

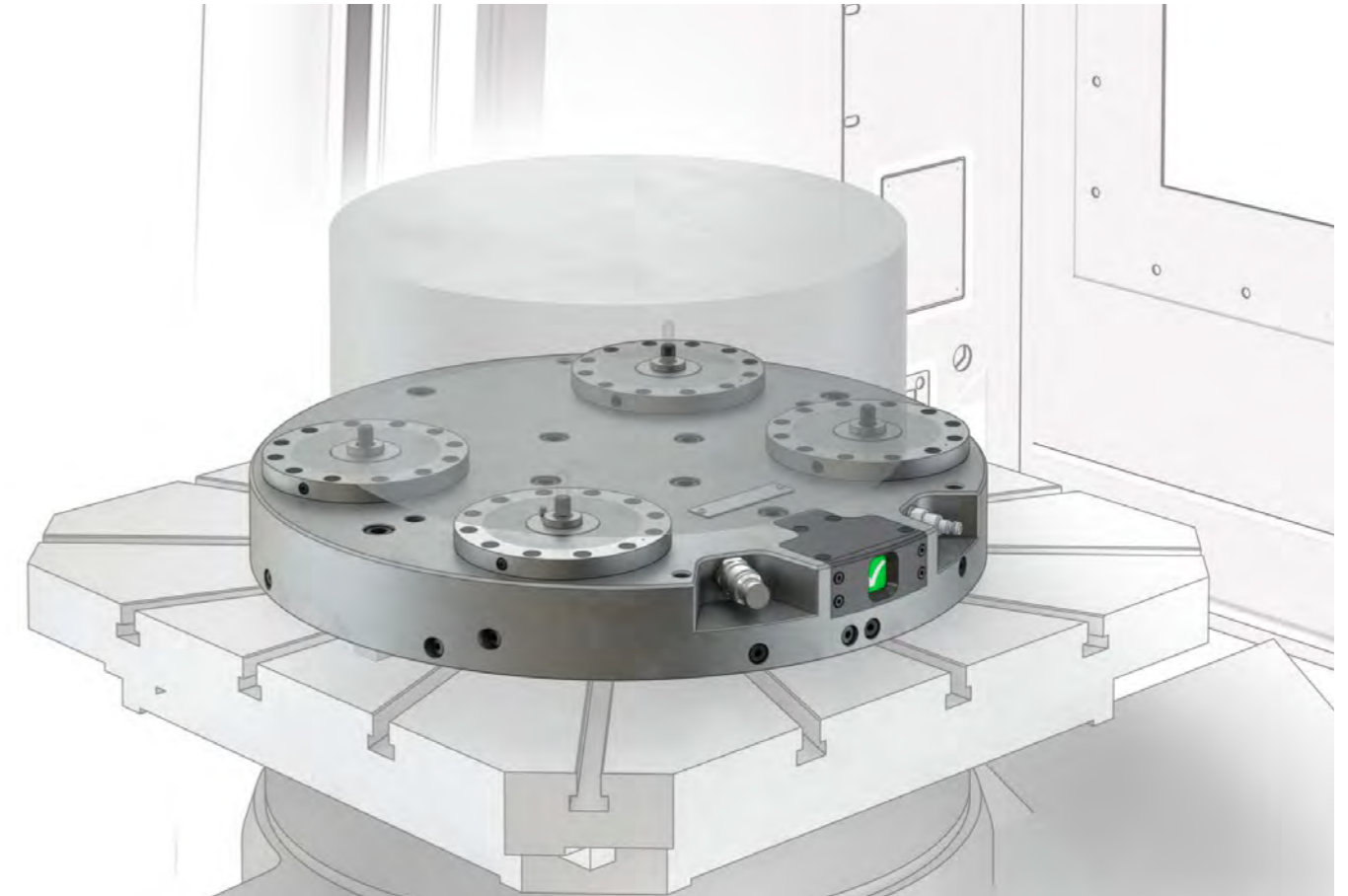

### Typical application for milling machines

- Zero point clamping system STARK.classic.NG.2
- Clamp control valve per clamping element
- Visual clamp control
- Seat check
- Easy handling

### System options and features

- Customer-specific spacing 300x200 mm
- Also suitable for direct workpiece clamping
- The clamp control safety feature can also be easily retrofitted thanks to the visual clamp control display

## STARK.CLASSIC.NG-S - SINGLE APPLICATION

STARK.classic.NG-S was specially developed for single clamping and 5-axis machining. This clamping element is ideal for manual and automated loading. A combination with the STARK.classic.NG clamping element is possible at any time. Versions with hydraulic and pneumatic actuation are available.

### BENEFITS

- For manual and automated loading
- Accurate to a  $\mu$
- Extremely high stiffness
- Form-fit is free of play due to spring-loaded pins
- Workpiece clamping via self-made adapter plates enables 5-sided accessibility

## STARK.classic.NG-S.2 D139, Twister



Fast closing clamp made of high-quality tool steel

- Installation element  $\varnothing 139$  mm, Twister, high-precision (without press fit) with locking function
- With release and seat check
- Clamp control optional

### Properties

- Retention force: 38,000 N
- Repeat accuracy: < 0.007 mm
- Installation acc. to Data Sheet D123
- Operating Manual WM-020-332-xx-xx

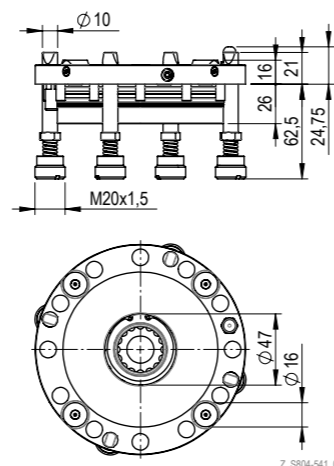

Plastic covers M6 S899-406 enclosed separately/cylinder screws with hexagon socket M6x16mm S931-138 enclosed separately/O-rings  $\varnothing 7 \times 1.5$ mm S833-043 enclosed separately/locking pin  $\varnothing 10 \times 58$ mm enclosed separately/compression springs S833-080 enclosed separately/spring holders M20x1.5x15mm enclosed separately/locking pin  $\varnothing 6$ mm S862-263 enclosed separately

Order number	Article designation	Function	Insertion force	Min. / max. release pressure	Weight
S804-541	SE N2 H 220 D139 TW NP IX HG	Hydraulic-releasing	22,000 N	40 bar / 80 bar	2.7 kg
S804-541-P	SE N2 P 025 D139 TW NP IX HG	Pneumatic-releasing	2,500 N	5 bar / 10 bar	2.3 kg

► Hardened support disc NG-S - see page 50-51

## Retractable nipple STARK.classic.NG-S.2 with zero point



Retractable nipple suitable for STARK.classic.NG-S.2 fast closing clamp

- Retractable nipple with zero point
- Special fit for NG-S
- Material: Tool steel
- Installation acc. to Data Sheet D029-2

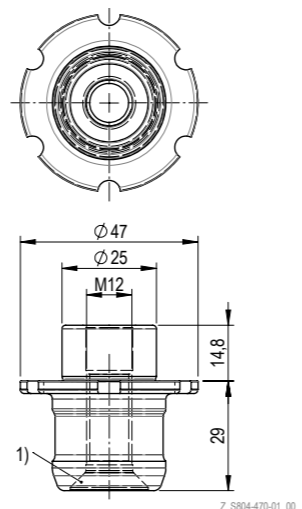

1) Countersink for M10 screw

Order number	Article designation	Area of application	Weight
S804-474-01	EB C2 NP 250 12 148 HG MK	STARK.classic.NG-S.2	0.19 kg

## Application example - Single application with STARK.classic.NG-S



STARK.classic.NG-S can be adapted to almost any machine via various adapters.



Extremely high stiffness due to form-fit that is free of play and high pre-tensioning force of the cup springs (hydraulic-releasing elements) or spiral springs (pneumatic-releasing elements).



The NG-S system is very economical as self-made pallets can also be used: minimum effort and maximum flexibility.

## Ways to increase precision

### When the requirement must be more precise than precise!

Our understanding of precision is the micrometre range: 1  $\mu$  corresponds to a thousandth of a millimetre and 5  $\mu$  is standard for us. With our in-depth and extensive industry know-how, we also offer opportunities to further increase accuracy in high-precision applications:

- **SHIMS**  
to compensate for cumulative tolerances
- **2  $\mu$  ACCURATE SUPPORT DISCS**  
maximum accuracy even after changing clamping elements
- **HG VERSIONS**  
high-precision due to press fit

### SHIM - EQUALISER OPTIONS FOR CUMULATIVE TOLERANCES



- Shims allow precise adjustment of the zero point clamping system (ZPC) in the Z plane.
- The shim is located between the fast closing plate (FCP) and the clamping element.
- After successful assembly of the fast closing plate, any height differences are determined. The shims can be ground according to the required tolerances. This procedure is repeated until the required tolerances are reached. This compensates for all cumulative tolerances of the machine, machine table and fast closing plate.
- **BENEFIT**  
In case of service, a clamping element can simply be exchanged for another one, without time-consuming adjustment work. When changing the clamping element, the shim is not replaced.
- Suitable for all clamping elements of the STARK.classic.NG product family.

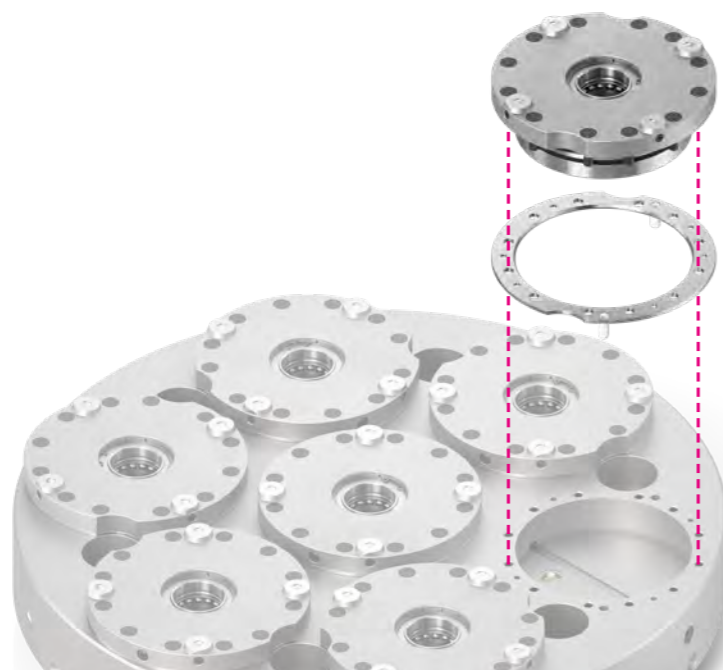

### 2 $\mu$ - PRECISE SUPPORT

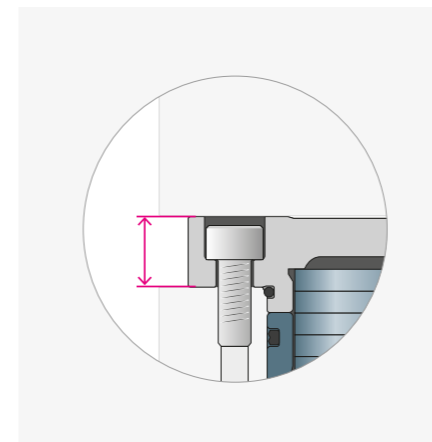

The great advantage of the 2  $\mu$  version is that in the event of servicing a high-precision system, no height adjustment is necessary when replacing elements and machine availability is optimised.

- For special requirements, the Twister design can be provided with a tolerance of 2  $\mu$ : particularly advantageous for high-precision, matched systems (e.g. clamping element changeover).
- Highest accuracy to reduce tolerance errors.
- The standard tolerance for the disc height of STARK clamping elements is 5  $\mu$ .

### HG - HIGH-PRECISION DUE TO PRESS FIT

The STARK.classic.NG HG high-precision clamping elements ensure maximum precision when changing devices from the set-up station to the machine or from machine to machine. This maximum precision is achieved by using a press fit between the HG clamping element and the HG retractable nipple. The HG retractable nipple is joined or lifted by means of active insertion and lifting of the STARK.classic system. The materials and heat treatments selected for this highly demanding field of application ensure durable and wear-free operation.

- Used in high precision applications in 5-axis or rotary applications in the centre of the fast closing plate, e.g. turbine engine parts ("aeronautical accuracy").
- HG versions ensure that the axis of rotation is located in the centre with maximum precision.

#### INFO

#### High-precision due to press fit

An high precision clamping element may only be combined with an high precision retractable nipple.

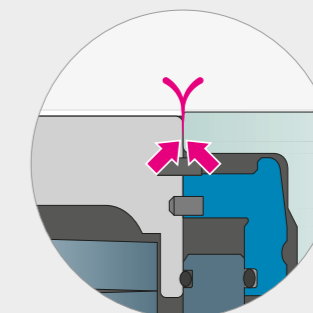

## Pre-assembly

The clamping elements of the STARK.classic.NG product family are delivered pre-assembled including transportation lock.

- **100 % FUNCTIONALLY SAFE**  
Simply plug in and screw tight
- **85 % TIME SAVING**  
Quick assembly
- **100 % SERVICE-FRIENDLY**  
Installation possible in any position

### INFO Pre-assembly

The pre-assembled STARK.classic.NG clamping elements are delivered with transportation lock and can be installed in any position

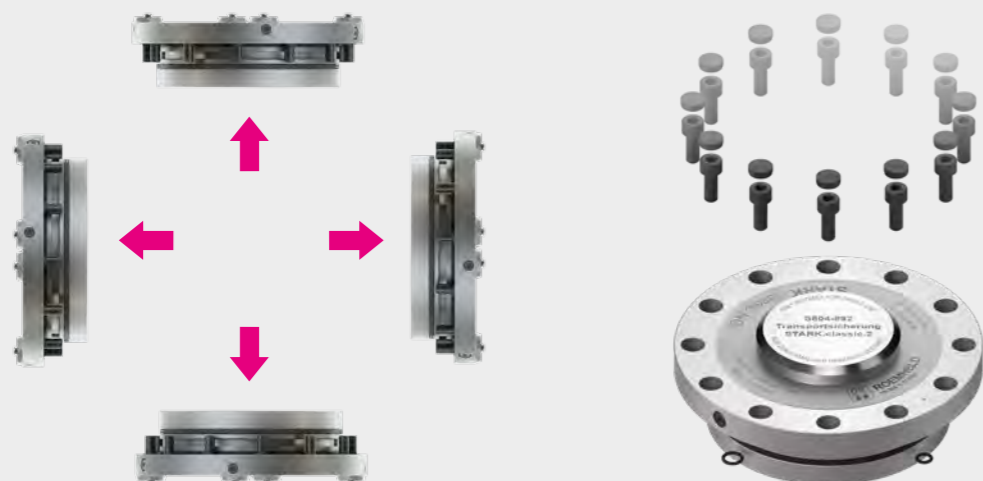

## Transportation lock

The transportation lock is designed for the transport as well as for the safe installation of the pre-assembled clamping elements. Once the clamping element has been installed, the transportation lock cannot be reused.

- Tempered steel material

Order number	Article designation	Weight
S804-891	Transportation lock C1/N1	0.14 kg
S804-892	Transportation lock C2/N2	0.33 kg
S804-893	Transportation lock C3/N3	0.72 kg

## Surface-mounted housing



Surface-mounted housing made of nitrided steel for assembly on machine table. Suitable for the STARK.classic.NG fast closing clamps

- Two-part version
- For installation, see Operating Manual WM-020-332-xx-xx

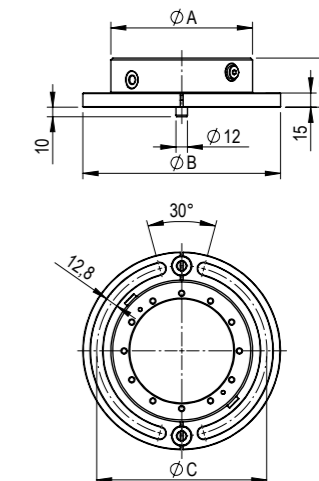

Z\_S804-965\_00

- Connection discs M6 S808-006 enclosed separately  
- Positioning pin Ø 12mm x 20mm S809-003 enclosed separately  
- Positioning clamps enclosed separately

Order number	Article designation	ØA	ØB	ØC	D	Connection Release	Release control connections	Transport thread	Weight
S804-965	Surface-mounted housing NG.1	112 mm	168 mm	140 mm	52 mm	1/8"	1/8"	-	3.74 kg
S804-966	Surface-mounted housing NG.2	150 mm	209 mm	180 mm	52 mm	1/8"	1/8"	-	6.3 kg
S804-967	Surface-mounted housing NG.3	190 mm	246 mm	218 mm	72 mm	1/4"	1/8"	2x M8	10.76 kg

### INFO Surface-mounted housing practical example

STARK.classic.NG surface-mounted housing with clamping ring and hydraulic connection.



## Clamp control

For safety reasons, a clamp control is strongly recommended for all high-speed applications. STARK.classic.NG clamping elements can be optionally equipped with a mechanical clamp control valve for this purpose. The evaluation of the clamp control can be integrated directly into the machine control system or can be displayed by means of a visual clamp control. Optionally, pressure boosters or hydraulic units with corresponding sensors can be connected to existing machines.

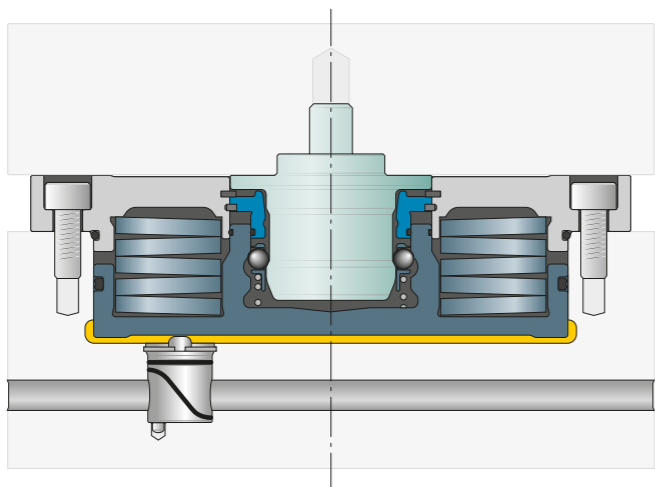

### INFO Functional explanation and connection diagram

By using the mechanical clamp control valve (2), the correct and secure clamping of the fast closing clamp is checked during each clamping process. If clamping is not correct or without a retractable nipple, the piston moves beyond the normal position and blocks the flow of the hydraulic line (3) with the clamp control valve.

On plates or in towers, all fast closing clamps are queried in series, so the exact clamping of all fast closing clamps can be checked at any time.

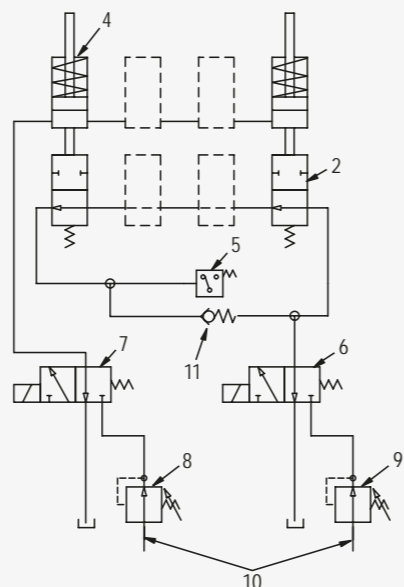
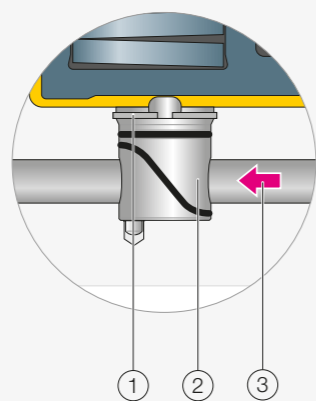

This connection diagram serves only as an example and explains the mode of operation

- 1) Lock ring
- 2) Clamp control valve
- 3) Direction of flow
- 4) Clamping element
- 5) Pressure switch for clamping signal
- 6) Hydraulic valve for clamp control
- 7) Hydraulic valve for releasing the element
- 8) Pressure relief valve, 40 bar (80 bar)
- 9) Pressure relief valve, 8 bar
- 10) Oil supply from machine
- 11) Non-return valve (bypass)

## Clamp control valve



Clamp control valve to ensure the correct clamping state

Clamp control valve must be used on all rotary machines. Especially for vertical change procedures and turning machines.

General recommendation for all zero point clamping systems: a safety benefit for every application.

#### Properties

- Max. pressure: 10 bar
- Installation acc. to Data Sheet D024
- Operating Manual WM-020-255-xx-xx

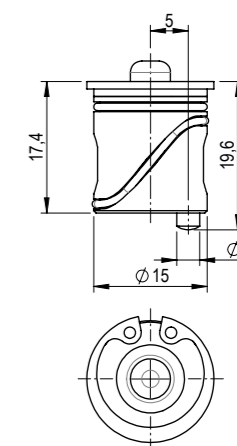

Z\_S704-210\_00

Order number	Article designation	Weight
S704-210	Clamp control valve	0.01 kg
S504-070	Clamp control valve installation aid	0.03 kg

► Clamp control valve installation aid - see page 71

### INFO Visual clamp control

Is the zero point clamping system securely clamped?

In many applications, e.g. when turning, clamp control is mandatory. The visual clamp control shows the position of the piston after activation of the clamp control in the fast closing clamp and provides absolutely reliable information via a traffic light signal.

Simple operation and easy retrofitting are major benefits with this safety component.

The visual clamp control can be integrated into the fast closing plate.



The green display shows that clamping is correct.

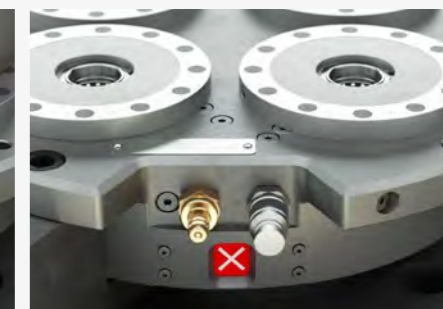

The display changes to red when releasing until positive clamp control occurs again.

## Visual clamp control



Visual clamp control for visualisation of the clamping state

Optionally, the visual clamp control is also available with an individual radius.

R min. = 175 mm (matching with outer radius of the fast closing plate).

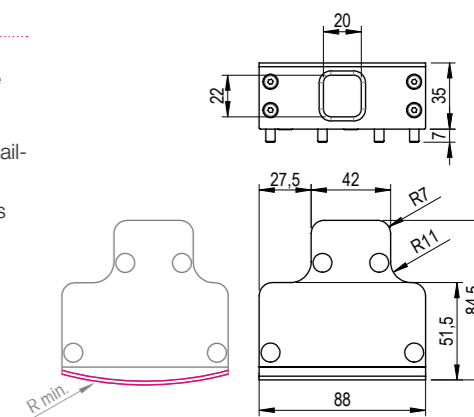

Order number	Article designation	Weight
S704-296	Visual clamp control (straight version)	0.58 kg



## Released control

Pneumatic release control is possible with standard elements of the STARK.classic.NG product family. The access lines to the clamping elements are supplied pneumatically via deep-hole bores. Here, the query can be realised via dynamic pressure / flow rate. The release control is recommended for applications with automation and heavy components.

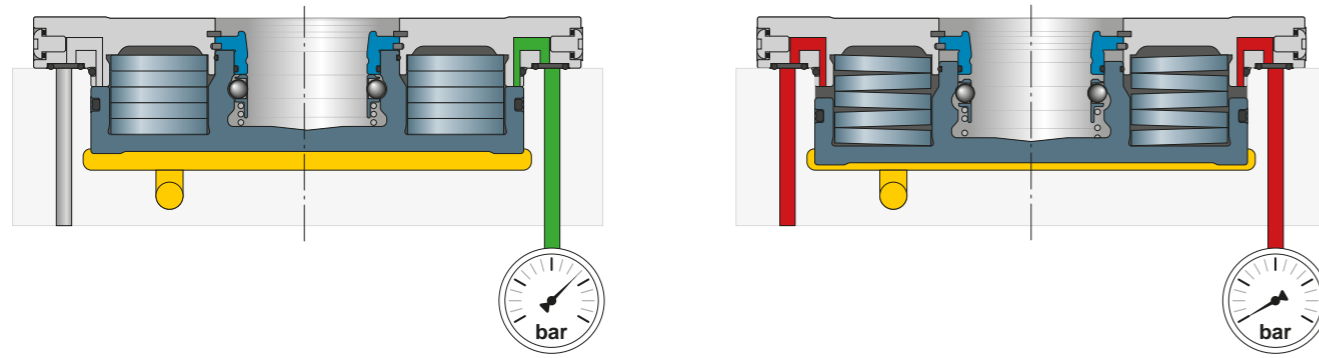

## Seat check

Pneumatic seat check is possible for standard elements of the STARK.classic.NG product family. The seat check works with dynamic pressure and is used for precision testing. The seat check is used to detect contamination between the pallet and the zero point clamping system.

Unlike the clamp control valve, the seat check is not a reliable safety feature. For safety-critical applications, clamp control is recommended (see page 31).

### INFO Dynamic pressure query

The dynamic pressure is queried via the island blow-off or the query bore.



### INFO Functional principle Blow-off and cleaning

Intelligent blow-out and blow-off technology for cleaning the support islands and the fitting bore. The blow-off takes place directly at the support surfaces and at the fitting diameter. To clean the support islands, air flows upward and mushroom-shaped downward via retractable nozzles.

- 1) Island blow-off
- 2) Centre blow-off
- 3) Island blow-off  
Nozzle functionality
- 4) Island blow-off  
Nozzle retracted
- 5) Island blow-off  
Nozzle extended
- 6) Openings for centre blow-off

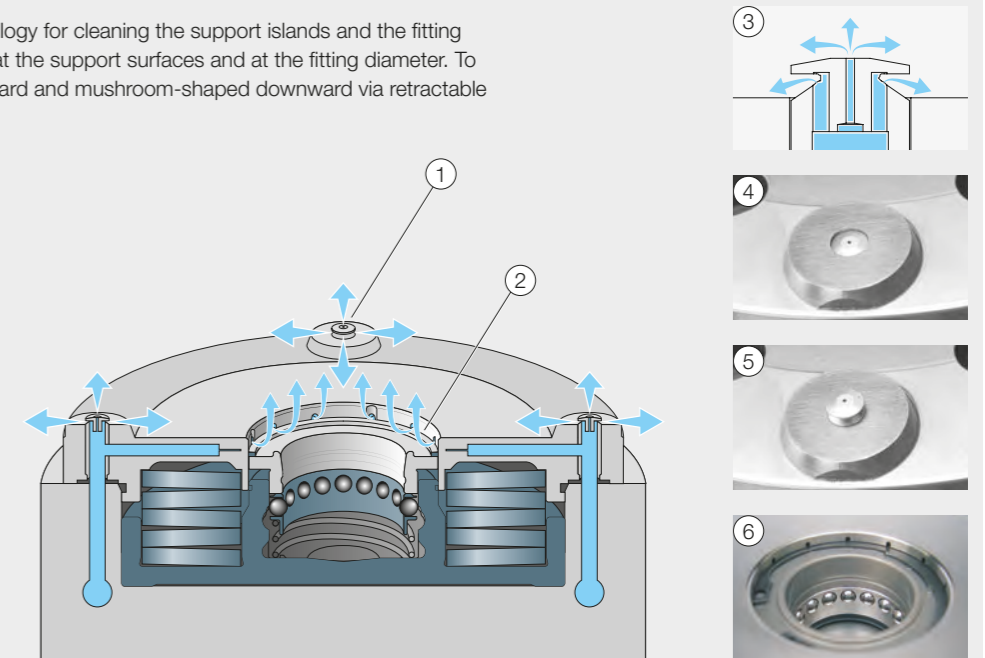

## Coolant outlet



The coolant outlet in the clamping element ensures that both fine chips and the coolant can drain through the fast closing plate (FCP).

This function is particularly necessary for EDM machines. Make sure that the fast closing plate is designed in such a way that the liquid can drain off between the fast closing plate and the machine table.

- With STARK.classic.NG Twister & Tornado no seat check is possible.
- ▶ Detailed information can be found in the hydraulic elements.

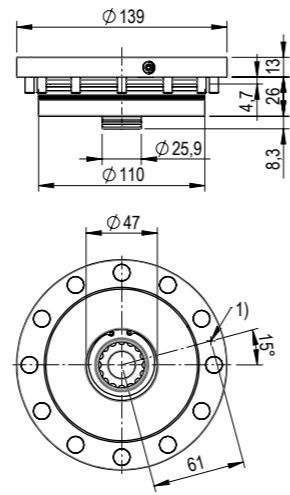

Z\_S804-538-03\_00

- 1) Seat check
- Plastic cover M6 S999-408, enclosed separately
  - Cylinder screw with hexagon socket M6x16mm S931-138, enclosed separately
  - O-rings  $\varnothing 7 \times 1.5$ mm S933-043, enclosed separately
  - O-ring  $\varnothing 5 \times 1.5$ mm S933-051, enclosed separately

Order number	Article designation example	Function
see Element Matrix <sup>1)</sup>	SE N2 H 220 D139 ST NP KA DH	Standard, coolant outlet

▶ <sup>1)</sup> Other versions with additional functions - see Element Matrix, page20

## Indexing



Indexing is used for clamping pallets via a single clamping element.

Individual clamping can be realised via indexing, alternatively via STARK.classic.NG-S (see chapter STARK.classic.NG-S).

- ▶ Detailed information can be found in the hydraulic elements.

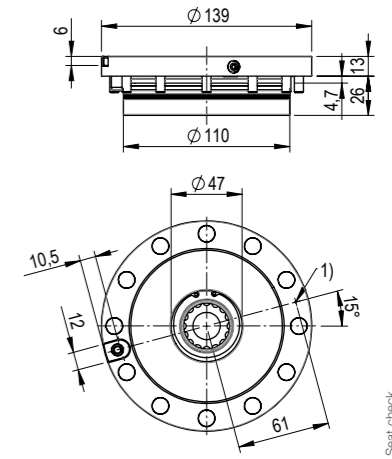

- 1) Seat check
- Plastic cover M6 S999-408, enclosed separately
  - Cylinder screw with hexagon socket M6 x 16mm S931-138, enclosed separately
  - O-rings  $\varnothing 7 \times 1.5$ mm S933-043, enclosed separately
  - O-ring  $\varnothing 5 \times 1.5$ mm S933-051, enclosed separately
  - Cylinder pin  $\varnothing 6 \times 16$ mm S880-097, enclosed separately

Order number	Article designation example	Function
see Element Matrix <sup>1)</sup>	SE N2 H 220 D139 ST NP IN DH	Standard, indexing

▶ <sup>1)</sup> Other versions with additional functions - see Element Matrix, page20

## Integrated media duct



For the passage of media such as oil, air, water, etc., STARK.classic.NG can be equipped with integrated media ducts on request. These are automatically positioned and coupled during clamping.

This allows, for example, clamping devices mounted on machine pallets to be supplied with energy (hydraulics, pneumatics, etc.). The coupling force is applied by the clamping element. With extremely simple handling, the pallet is positioned, clamped and coupled fully automatically.

- ▶ Detailed information can be found in the hydraulic elements.

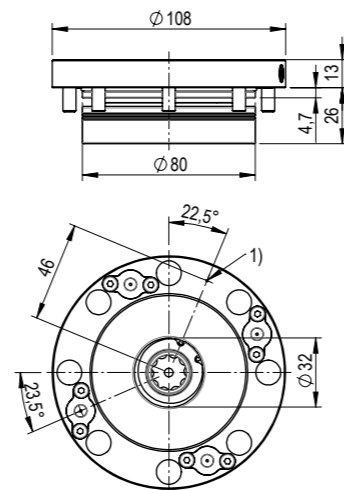

Z\_S804-538\_00

- 1) Seat check
- Screw covers M6 S704-231, enclosed separately
  - Cylinder screws with hexagon socket M6x16mm S931-138, enclosed separately
  - O-rings  $\varnothing 5 \times 1.5$ mm S933-051, enclosed separately

Order number	Article designation example	Function
see Element Matrix <sup>1)</sup>	SE N1 H 080 D108 ST NP MD4	Standard with 4x media duct

▶ <sup>1)</sup> Other versions with additional functions - see Element Matrix, page20

### INFO Indexing

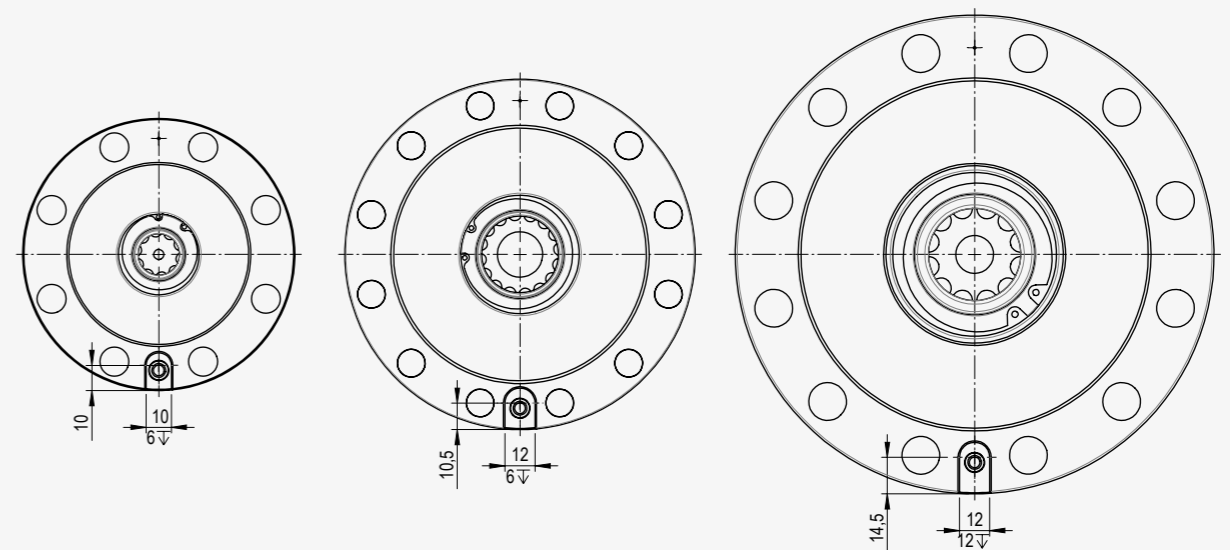

STARK.classic.NG.1

STARK.classic.NG.2

STARK.classic.NG.3

## RETRACTABLE NIPPLE NG.1

### STARK.classic.1 retractable nipple with zero point



Retractable nipple suitable for all fast closing clamps of the STARK.classic.1 and the STARK.classic.NG.1 family

- Retractable nipple with zero point
- Material: Tool steel
- Installation acc. to Data Sheet D029-1

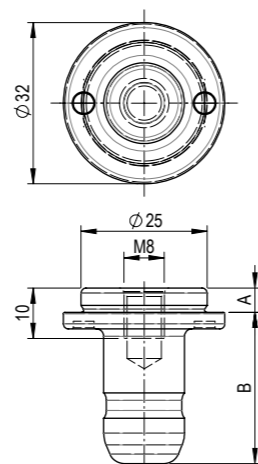

Z\_S804-209\_00

Order number	Article designation	Area of application/special feature	Collar A	Length B	Weight
S804-209	EB C1 NP 250 08 048	Standard	4.8 mm	30 mm	0.07 kg
S804-209K	EB C1 NK 250 08 048	Standard without lifting <sup>1</sup>	4.8 mm	28.5 mm	0.07 kg
S02637	EB C1 NP 250 08 128	With hardened support disc <sup>2</sup>	12.8 mm	30 mm	0.1 kg
S02942	EB C1 NP 250 08 048 MK	Standard with air recess <sup>3</sup>	4.8 mm	30 mm	0.07 kg
S03384	EB C1 NK 250 08 128	With hardened support disc <sup>2</sup> without lifting <sup>1</sup>	12.8 mm	28.5 mm	0.1 kg
S02637-11	EB C1 NP 250 08 128 MK	With hardened support disc <sup>2</sup> with air recess <sup>3</sup>	12.8 mm	30 mm	0.1 kg
S804-209HG	EB C1 NP 250 08 048 HG	Standard high-precision <sup>4</sup>	4.8 mm	30 mm	0.07 kg
S804-211HG	EB C1 NP 250 08 078 HG	With hardened pallet <sup>2</sup> and high-precision <sup>4</sup>	7.8 mm	30 mm	0.07 kg
S804-213HG	EB C1 NP 250 08 128 HG	With hardened support disc <sup>2</sup> and high-precision <sup>4</sup>	12.5 mm	30 mm	0.1 kg

- ▶ <sup>1</sup> Retractable nipple without lifting - see page 43
- ▶ <sup>2</sup> Hardened support disc - see page 50-51
- ▶ <sup>3</sup> Retractable nipple with air recess - see page 43
- ▶ <sup>4</sup> High-precision (HG) functional description - see page 27

### STARK.classic.1 retractable nipple without centring



Retractable nipple suitable for all fast closing clamps of the STARK.classic.1 and the STARK.classic.NG.1 family

- Retractable nipple without centring
- Material: Tool steel
- Installation acc. to Data Sheet D029-1

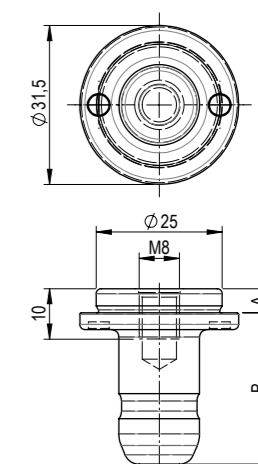

Z\_S804-238\_00

Order number	Article designation	Area of application/special feature	Collar A	Length B	Weight
S804-238	EB C1 OZ 250 08 048	Standard	4.8 mm	30 mm	0.07 kg
S804-238K	EB C1 OK 250 08 048	Standard without lifting <sup>1</sup>	4.8 mm	28.5 mm	0.07 kg
S02637-02	EB C1 OZ 250 08 128	With hardened support disc <sup>2</sup>	12.8 mm	30 mm	0.1 kg
S03386	EB C1 OK 250 08 128	With hardened support disc <sup>2</sup> without lifting <sup>1</sup>	12.8 mm	28.5 mm	0.1 kg

- ▶ <sup>1</sup> Retractable nipple without lifting - see page 43
- ▶ <sup>2</sup> Hardened support disc - see page 50-51

### STARK.classic.1 retractable nipple with equaliser



Retractable nipple suitable for all fast closing clamps of the STARK.classic.1 and the STARK.classic.NG.1 family

- Retractable nipple with equaliser
- Material: Tool steel
- Installation acc. to Data Sheet D029-1 / D029-5

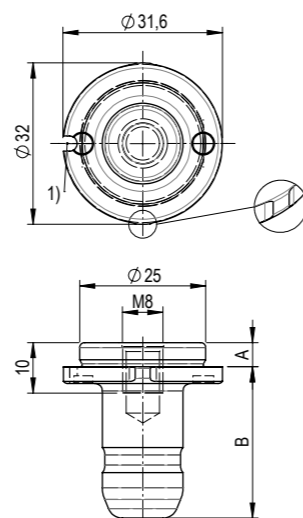

Z\_S804-230\_00

1) Groove for clamping pin Ø2.5x6 for indexing  
- Clamping pin included in scope of delivery

Order number	Article designation	Area of application/special feature	Collar A	Length B	Weight
S804-230	EB C1 AG 250 08 048	Standard	4.8 mm	30 mm	0.07 kg
S804-230K	EB C1 AK 250 08 048	Standard without lifting <sup>1</sup>	4.8 mm	28.5 mm	0.07 kg
S02637-01	EB C1 AG 250 08 128	With hardened support disc <sup>2</sup>	12.8 mm	30 mm	0.1 kg
S03385	EB C1 AK 250 08 128	With hardened support disc <sup>2</sup> without lifting <sup>1</sup>	12.8 mm	28.5 mm	0.1 kg

- ▶ <sup>1</sup> Retractable nipple without lifting - see page 43
- ▶ <sup>2</sup> Hardened support disc - see page 50-51

## RETRACTABLE NIPPLE NG.2

### STARK.classic.2 retractable nipple with zero point



Retractable nipple suitable for all fast closing clamps of the STARK.classic.2 and the STARK.classic.NG.2 family

- Retractable nipple with zero point
- Material: Tool steel
- Installation acc. to Data Sheet D029-2

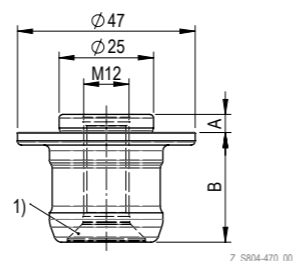

1) Countersink for M10 screw

Order number	Article designation	Area of application/special feature	Collar A	Length B	Weight
S804-470	EB C2 NP 250 12 048	Standard	4.8 mm	29 mm	0.17 kg
S804-470K	EB C2 NK 250 12 048	Standard without lifting <sup>1</sup>	4.8 mm	27.5 mm	0.17 kg
S804-474	EB C2 NP 250 12 148	With hardened support disc <sup>2</sup>	14.8 mm	29 mm	0.19 kg
S804-470-02	EB C2 NP 250 12 048 MK	Standard with air recess <sup>3</sup>	4.8 mm	29 mm	0.17 kg
S804-474K	EB C2 NK 250 12 148	With hardened support disc <sup>2</sup> without lifting <sup>1</sup>	14.8 mm	27.5 mm	0.19 kg
S804-474-02	EB C2 NP 250 12 148 MK	With hardened support disc <sup>2</sup> with air recess <sup>3</sup>	14.8 mm	29 mm	0.19 kg
S804-470HG	EB C2 NP 250 12 048 HG	Standard high-precision <sup>4</sup>	4.8 mm	29 mm	0.17 kg
S804-469HG	EB C2 NP 250 12 078 HG	With hardened pallet <sup>2</sup> and high-precision <sup>4</sup>	7.8 mm	29 mm	0.17 kg
S804-474HG	EB C2 NP 250 12 148 HG	With hardened support disc <sup>2</sup> and high-precision <sup>4</sup>	14.8 mm	29 mm	0.19 kg

- ▶ <sup>1</sup> Retractable nipple without lifting - see page 43
- ▶ <sup>2</sup> Hardened support disc - see page 50-51
- ▶ <sup>3</sup> Retractable nipple with air recess - see page 43
- ▶ <sup>4</sup> High-precision (HG) functional description - see page 27

### STARK.classic.2 retractable nipple with equaliser



Retractable nipple suitable for all fast closing clamps of the STARK.classic.2 and the STARK.classic.NG.2 family

- Retractable nipple with equaliser
- Material: Tool steel
- Installation acc. to Data Sheet D029-2/ D029-5

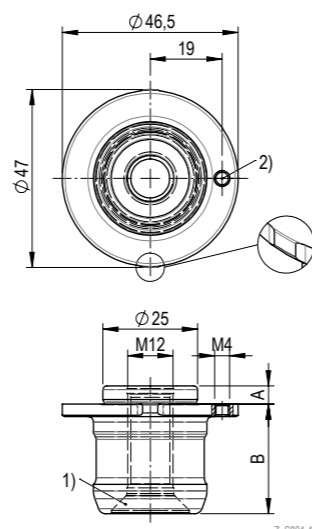

1) Countersink for M10 screw  
2) Thread for shaft screw M4 x 8 for indexing - Shaft screw included in scope of delivery

Order number	Article designation	Area of application/special feature	Collar A	Length B	Weight
S804-471	EB C2 AG 250 12 048	Standard	4.8 mm	29 mm	0.17 kg
S804-471K	EB C2 AK 250 12 048	Standard without lifting <sup>1</sup>	4.8 mm	27.5 mm	0.17 kg
S804-476	EB C2 AG 250 12 148	With hardened support disc <sup>2</sup>	14.8 mm	29 mm	0.19 kg
S804-476K	EB C2 AK 250 12 148	With hardened support disc <sup>2</sup> without lifting <sup>1</sup>	14.8 mm	27.5 mm	0.19 kg

- ▶ <sup>1</sup> Retractable nipple without lifting - see page 43
- ▶ <sup>2</sup> Hardened support disc - see page 50-51

### STARK.classic.2 retractable nipple without centring



Retractable nipple suitable for all fast closing clamps of the STARK.classic.2 and the STARK.classic.NG.2 family

- Retractable nipple without centring
- Material: Tool steel
- Installation acc. to Data Sheet D029-2

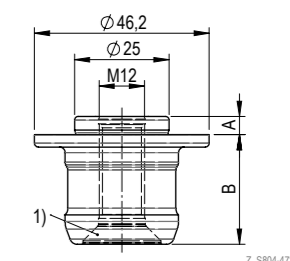

1) Countersink for M10 screw

Order number	Article designation	Area of application/special feature	Collar A	Length B	Weight
S804-472	EB C2 OZ 250 12 048	Standard	4.8 mm	29 mm	0.17 kg
S804-472K	EB C2 OK 250 12 048	Standard without lifting <sup>1</sup>	4.8 mm	27.5 mm	0.17 kg
S804-478	EB C2 OZ 250 12 148	With hardened support disc <sup>2</sup>	14.8 mm	29 mm	0.19 kg
S804-478K	EB C2 OK 250 12 148	With hardened support disc <sup>2</sup> without lifting <sup>1</sup>	14.8 mm	27.5 mm	0.19 kg

- ▶ <sup>1</sup> Retractable nipple without lifting - see page 43
- ▶ <sup>2</sup> Hardened support disc - see page 50-51

## RETRACTABLE NIPPLE NG.3

### STARK.classic.3 retractable nipple with zero point



Retractable nipple suitable for all fast closing clamps of the STARK.classic.3 and the STARK.classic.NG.3 family

- Retractable nipple with zero point
- Material: Tool steel
- Installation acc. to Data Sheet D029-2

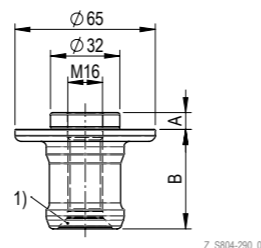

Z\_S804-290\_00

1) Countersink for M12 screw

Order number	Article designation	Area of application/special feature	Collar A	Length B	Weight
S804-290	EB C3 NP 320 16 078	Standard	7.8 mm	46 mm	0.40 kg
S804-290K	EB C3 NK 320 16 078	Standard without lifting <sup>1</sup>	7.8 mm	44.3 mm	0.40 kg
S04156	EB C3 NP 320 16 248	With hardened support disc <sup>2</sup>	24.8 mm	46 mm	0.48 kg
S804-290-01	EB C3 NP 320 16 078 MK	Standard with air recess <sup>3</sup>	7.8 mm	46 mm	0.40 kg
S804-312K	EB C3 NK 320 16 248	With hardened support disc <sup>2</sup> without lifting <sup>1</sup>	24.8 mm	44.3 mm	0.48 kg
S804-312-01	EB C3 NP 320 16 248 MK	With hardened support disc <sup>2</sup> with air recess <sup>3</sup>	24.8 mm	46 mm	0.48 kg
S804-290HG	EB C3 NP 320 16 078 HG	With hardened pallet <sup>2</sup> and high-precision <sup>4</sup>	7.8 mm	46 mm	0.40 kg
S03641	EB C3 NP 320 16 248 HG	With hardened support disc <sup>2</sup> and high-precision <sup>4</sup>	24.8 mm	46 mm	0.48 kg

- ▶ <sup>1</sup> Retractable nipple without lifting - see page 43
- ▶ <sup>2</sup> Hardened support disc - see page 50-51
- ▶ <sup>3</sup> Retractable nipple with air recess - see page 43
- ▶ <sup>4</sup> High-precision (HG) functional description - see page 27

### STARK.classic.3 retractable nipple without centring



Retractable nipple suitable for all fast closing clamps of the STARK.classic.3 and the STARK.classic.NG.3 family

- Retractable nipple without centring
- Material: Tool steel
- Installation acc. to Data Sheet D029-2

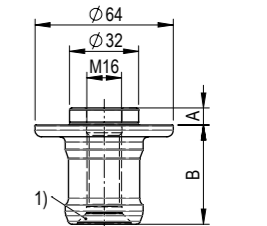

Z\_S804-294\_00

1) Countersink for M12 screw

Order number	Article designation	Area of application/special feature	Collar A	Length B	Weight
S804-294	EB C3 OZ 320 16 078	Standard	7.8 mm	46 mm	0.40 kg
S804-294K	EB C3 OK 320 16 078	Standard without lifting <sup>1</sup>	7.8 mm	44.3 mm	0.40 kg
S03660	EB C3 OZ 320 16 248	With hardened support disc <sup>2</sup>	24.8 mm	46 mm	0.48 kg
S804-314K	EB C3 OK 320 16 248	With hardened support disc <sup>2</sup> without lifting <sup>1</sup>	24.8 mm	44.3 mm	0.48 kg

- ▶ <sup>1</sup> Retractable nipple without lifting - see page 43
- ▶ <sup>2</sup> Hardened support disc - see page 50-51

### STARK.classic.3 retractable nipple with equaliser



Retractable nipple suitable for all fast closing clamps of the STARK.classic.3 and the STARK.classic.NG.3 family

- Retractable nipple with equaliser
- Material: Tool steel
- Installation acc. to Data Sheet D029-2/ D029-5

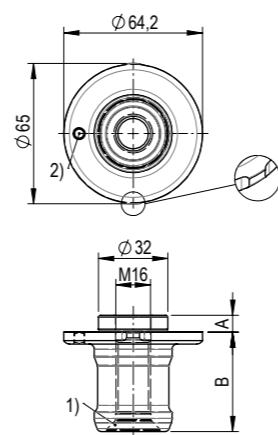

Z\_S804-292\_00

1) Countersink for M12 screw  
2) Thread for shaft screw M5x25 for indexing  
- Shaft screw included in scope of delivery

Order number	Article designation	Area of application/special feature	Collar A	Length B	Weight
S804-292	EB C3 AG 320 16 078	Standard	7.8 mm	46 mm	0.40 kg
S804-292K	EB C3 AK 320 16 078	Standard without lifting <sup>1</sup>	7.8 mm	44.3 mm	0.40 kg
S03642	EB C3 AG 320 16 248	With hardened support disc <sup>2</sup>	24.8 mm	46 mm	0.48 kg
S804-313K	EB C3 AK 320 16 248	With hardened support disc <sup>2</sup> without lifting <sup>1</sup>	24.8 mm	44.3 mm	0.48 kg

- ▶ <sup>1</sup> Retractable nipple without lifting - see page 43
- ▶ <sup>2</sup> Hardened support disc - see page 50-51

## Equaliser via retractable nipple

A zero-point clamping system consists of a fast closing clamp into which a retractable nipple is clamped. Three different retractable nipples are combined to equalise manufacturing tolerances and the necessary "mobility for thermal expansion" on a pallet "temperature variation of a workpiece":



**Retractable nipple with zero point (NP)**



**Retractable nipple with equaliser (AG)** equalisation of theoretical centre in equaliser direction



**Retractable nipple without centring (OZ)** equaliser of theoretical centre in all directions

### INFO Equalisation principle

#### Field of application

- Different materials between pallet and plate
- Flexible for different pallet sizes
- Manufacturing tolerances for cost-effective production

#### Application example - equalisation principle

- Fast closing plate with 6 clamping elements
- Device pallet with 6 retractable nipples
  - > 1x retractable nipple with zero point (NP)
  - > 1x retractable nipple with equaliser (AG)
  - > 4x retractable nipple without centering (OZ)

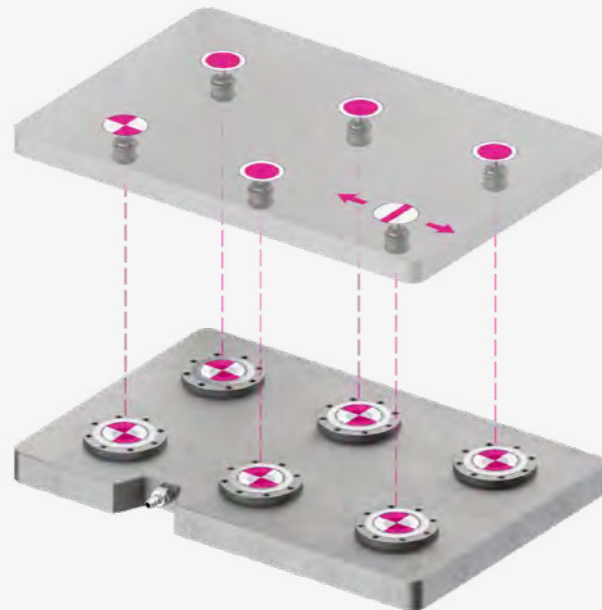

#### Symbols – equaliser function

- with zero point (NP)
- with equaliser (AG)
- without centring (OZ)

## Retractable nipple with air recess

The air recess prevents the pallet from rattling when the blow-out air is active. The compressed air can escape in a controlled manner through the recesses on the zero point nipple. Thus, the blow-out can remain activated even during the clamping process. This ensures optimum cleaning even in automated operation.

### INFO Air recess

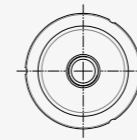

STARK.classic.NG.1

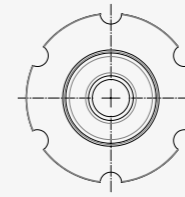

STARK.classic.NG.2  
STARK.classic.NG-S.2

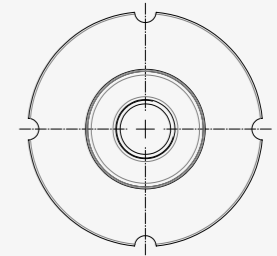

STARK.classic.NG.3

## Short retractable nipple without lifting out of the fit

The release cycle of the STARK.classic.NG product family can be carried out with or without lifting from the fit. The release cycle with lifting (1) is achieved with "standard" retractable nipple. Release cycle without lifting (2) is carried out with "short" retractable nipple.

#### When is the "short" retractable nipple used?

If the STARK.classic.NG is released, the "released" signal only occurs when the piston has reached the end position and the retractable nipple has been lifted. If lifting during release is not possible, e.g. due to the handling situation (the force acting against the lifting force is greater than the lifting force), the "released" piston position is not reached. This is avoided with the shortened retractable nipple. The piston reliably reaches the "released" position without the retractable nipple affecting the piston's freedom of movement.

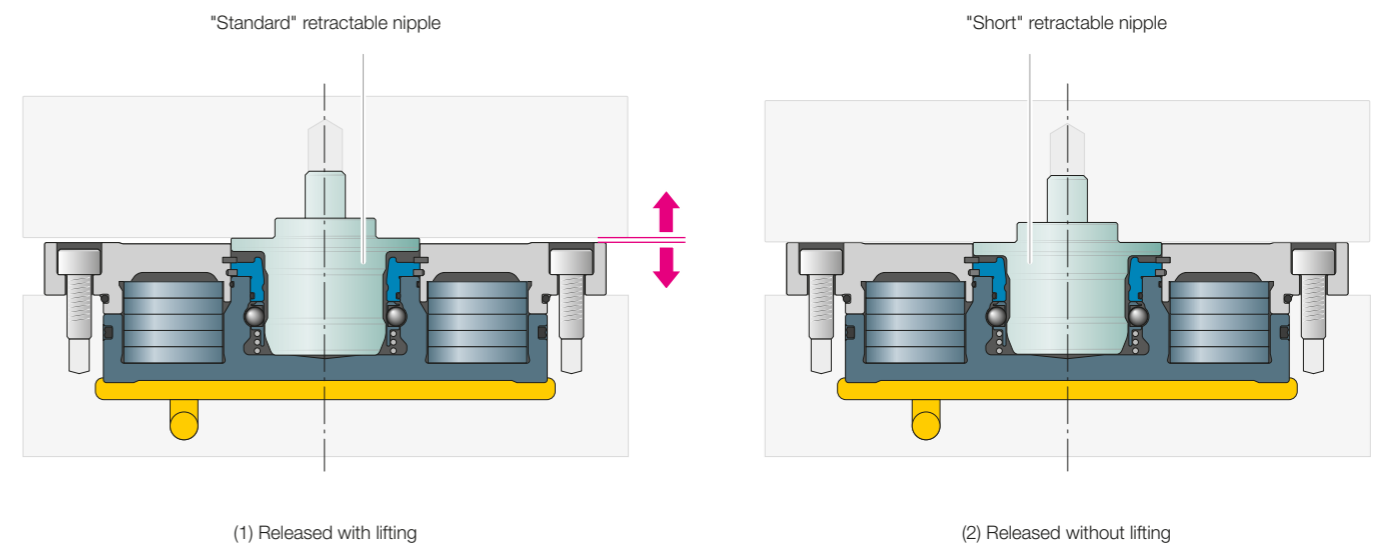

## PENDULUM NIPPLE

### Flange STARK.classic.1 - NP



Mounting flange with zero point for pendulum nipple

- Areas of application:  
Machine pallets, machine vice, chucks, fixtures, workpiece direct clamping
- Installation acc. to Data Sheet D030

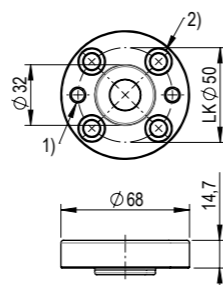

Z\_S801-010\_00

1) Pulling-off thread M6  
2) Countersink for M6 DIN 912 / ISO 4762

Order number	Article designation	Area of application/ special feature	Weight
S801-010	Mounting flange C1 NP	Standard, Tornado	0.2 kg

### Flange STARK.classic.1 - AG



Mounting flange with equaliser for pendulum nipple

- Areas of application:  
Machine pallets, machine vice, chucks, fixtures, workpiece direct clamping
- Installation acc. to Data Sheet D030

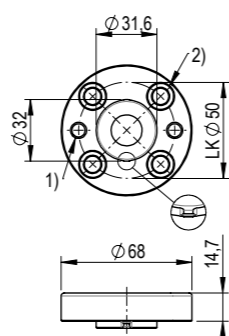

Z\_S801-011\_00

1) Pulling-off thread M6  
2) Countersink for M6 DIN 912 / ISO 4762

Order number	Article designation	Area of application/ special feature	Weight
S801-011	Mounting flange C1 AG	Standard, Tornado	0.2 kg

### Flange STARK.classic.1 - OZ



Mounting flange without centring for pendulum nipple

- Areas of application:  
Machine pallets, machine vice, chucks, fixtures, workpiece direct clamping
- Installation acc. to Data Sheet D030

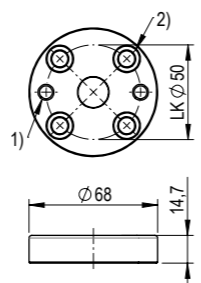

Z\_S801-012\_00

1) Pulling-off thread M6  
2) Countersink for M6 DIN 912 / ISO 4762

Order number	Article designation	Area of application/ special feature	Weight
S801-012	Mounting flange C1 OZ	Standard, Tornado	0.2 kg

### STARK.classic.1 pendulum nipple



Pendulum nipple for mounting flange

- Areas of application:  
Machine pallets, machine vice, chucks, fixtures, workpiece direct clamping
- Suitable for S801-010/-011/-012

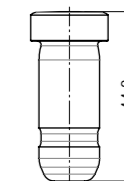

Z\_S801-009\_00

Order number	Article designation	Weight
S801-009	C1 pendulum nipple	0.2 kg

#### INFO

#### Pendulum nipple

The pendulum nipple is movable and mounted in a flange to prevent possible tilting when changing pallets (especially with heavy components and large machine pallets). It is only used for machine pallet or workpiece feed, positioning and centring is done via the zero point and compensation flange.

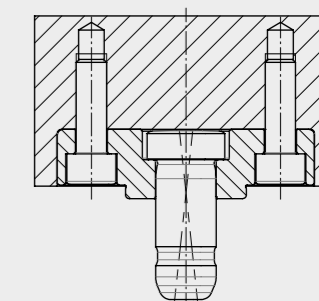

#### INFO

#### Advantages and benefits Retractable nipple STARK.classic floating function

##### ■ Low production costs

For large spacings, the advantage of a large equalisation can lead to much cheaper manufacture and thus significant cost savings. There are no processing steps and therefore the throughput time for the production of fast closing plates and pallets is reduced.

##### ■ Thermal expansion

Temperature changes, e.g. night 17°C / day 32°C, require special precautions to prevent redundant dimensioning (e.g. in the case of aluminium, a change in temperature of 15°C modifies spacing from 1000 mm to 1000.36 mm).

##### ■ Manufacturing tolerances

Due to the large equalisation, it is sufficient to prepare the position of the elements and retractable nipples with generous tolerances. The entire system is always zero point accurate.

##### You determine the zero point.

Zero point and axis alignment are retained and are always known. A total of up to ±2 mm can be compensated.

#### Retractable nipple AG

Floating range in the direction of the arrow

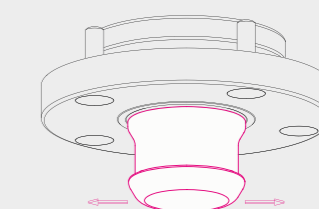

Schematic diagram

#### Retractable nipple NP and OZ

Floating range in the direction of the arrow (radial in all directions)

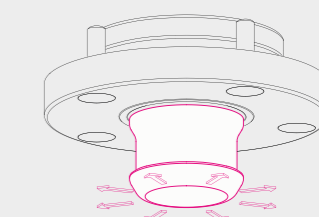

Schematic diagram

FLOATING NIPPLE

Retractable nipple STARK.classic.2 floating function - NP



Flange retractable nipple suitable for all fast closing clamps of the STARK.classic.2 and the STARK.classic.NG.2 family

- Flange retractable nipple with zero point,  $\varnothing 47$  mm: without floating range  
Retractable nipple front part: floating range of  $\pm 1.5$  mm
- Installation acc. to Data Sheet D143

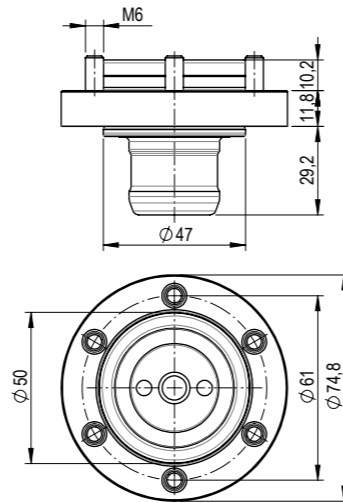

Z\_S804-480\_00

Order number	Article designation	Area of application/ special feature	Weight
S804-480	Flange retractable nipple C2 NP	Standard, Tornado	0.7 kg

Retractable nipple STARK.classic.2 floating function - AG



Flange retractable nipple suitable for all fast closing clamps of the STARK.classic.2 and the STARK.classic.NG.2 family

- Flange retractable nipple with equaliser in one axis, floating range of  $\pm 1.5$  mm
- Installation acc. to Data Sheet D143

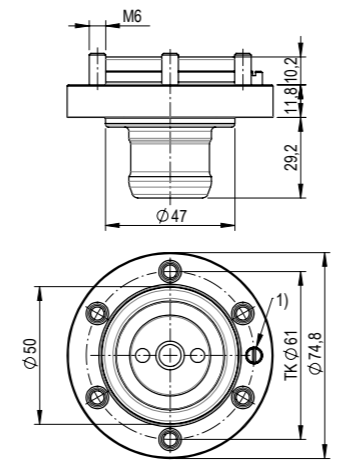

Z\_S804-481\_00

Order number	Article designation	Area of application/ special feature	Weight
S804-481	Flange retractable nipple C2 AG	Standard, Tornado	0.7 kg

Retractable nipple STARK.classic.2 floating function - OZ



Flange retractable nipple suitable for all fast closing clamps of the STARK.classic.2 and the STARK.classic.NG.2 family

- Flange retractable nipple without centring, floating range of  $\pm 1.5$  mm
- Installation acc. to Data Sheet D143

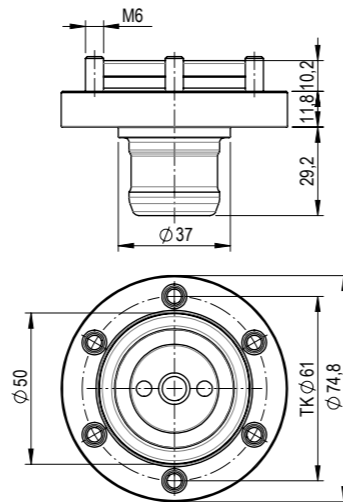

Z\_S804-482\_00

Order number	Article designation	Area of application/ special feature	Weight
S804-482	Flange retractable nipple C2 OZ	Standard, Tornado	0.7 kg

Retractable nipple STARK.classic.3 floating function - NP



Flange retractable nipple suitable for all fast closing clamps of the STARK.classic.3 and the STARK.classic.NG.3 family

- Flange retractable nipple with zero point,  $\varnothing 65$  mm: without floating range  
Retractable nipple front part: floating range of  $\pm 2$  mm
- Installation acc. to Data Sheet D163

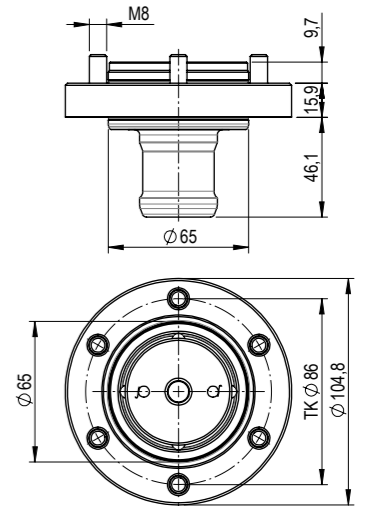

Z\_S804-592\_00

Order number	Article designation	Area of application/ special feature	Weight
S804-592	Flange retractable nipple C3 NP	Standard, Tornado	2.4 kg

Retractable nipple STARK.classic.3 floating function - AG



Flange retractable nipple suitable for all fast closing clamps of the STARK.classic.3 and the STARK.classic.NG.3 family

- Flange retractable nipple with equaliser in one axis,  
Retractable nipple front part: floating range of  $\pm 2$  mm
- Installation acc. to Data Sheet D163

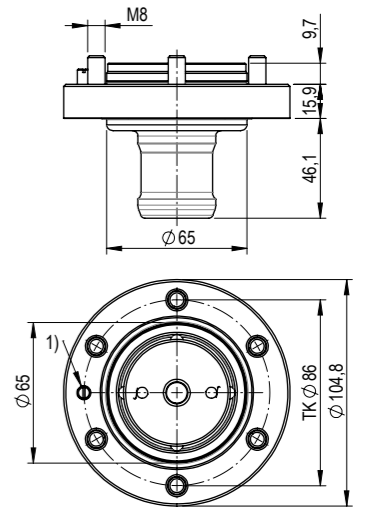

Z\_S804-590\_00

Order number	Article designation	Area of application/ special feature	Weight
S804-590	Flange retractable nipple C3 AG	Standard, Tornado	2.4 kg

Retractable nipple STARK.classic.3 floating function - OZ



Flange retractable nipple suitable for all fast closing clamps of the STARK.classic.3 and the STARK.classic.NG.3 family

- Flange retractable nipple without centring  
Retractable nipple front part: floating range of  $\pm 2$  mm
- Installation acc. to Data Sheet D163

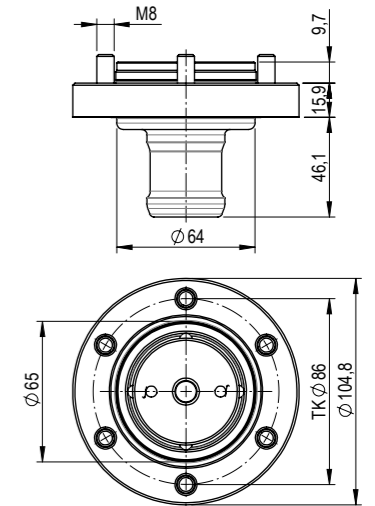

Z\_S804-591\_00

Order number	Article designation	Area of application/ special feature	Weight
S804-591	Flange retractable nipple C3 OZ	Standard, Tornado	2.4 kg



## NIPPLE FASTENING

### Nipple fastening D



For mounting the retractable nipple according to fastening option "D".

- Enables the nipple fastening bore to be produced from above in one clamping procedure
- Mounting key or face wrench recommended for counterholding
- Installation acc. to Data Sheet D029
- Operating Manual WM-020-332-xx-xx

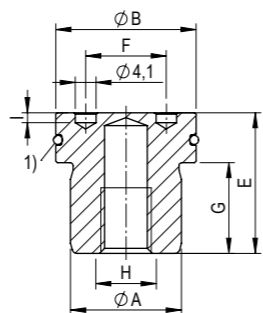

Z\_Nippelbefestigung\_D\_00

1) O-ring included in scope of delivery

Order number	Article designation	Size	ØA**	ØB	E	F	G	H	I	Weight
S804-252	NB 30 22 25 12 M08 NI D	NG.1	Ø25	Ø29.8	21.9	24	12	M8 × 13	3	0.09 kg
S804-267	NB 30 22 25 12 M10 NI D	NG.2	Ø25	Ø29.8	21.9	24	12	M10 × 13	3	0.09 kg
S804-262	NB 38 28 32 18 M12 NI D	NG.3	Ø32	Ø37.8	27.9	24	18	M12 × 18	2	0.18 kg

► \*\*ØA should correspond to the collar Ø of the retractable nipple

### Nipple fastening E



For mounting the retractable nipple according to fastening option "E".

- Enables the nipple fastening bore to be produced from above in one clamping procedure
- Installation acc. to Data Sheet D029-1
- Operating Manual WM-020-332-xx-xx

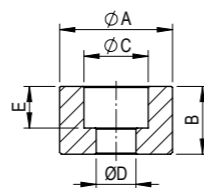

Z\_Nippelbefestigung\_E\_00

Order number	Article designation	Size	ØA	B	ØC	ØD	E	Weight
S804-250	NB 30 15 00 00 F08 NI E	NG.1	Ø29.8	14.9	Ø15	Ø8.5	9	0.07 kg

### Nipple fastening E.1



For mounting the retractable nipple according to fastening option "E.1".

- Enables the nipple fastening bore to be produced from above in one clamping procedure
- Mounting key or face spanner recommended for holding in place.
- Installation acc. to Data Sheet D029-2
- Operating Manual WM-020-332-xx-xx

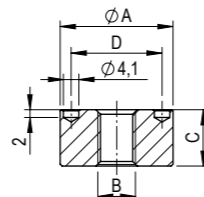

Z\_Nippelbefestigung\_E.1\_00

Order number	Article designation	Size	ØA	B	C	D	Weight
S804-266	NB 30 15 00 00 M10 NI E1	NG.2	Ø29.8	M10	14.9	24	0.05 kg
S804-264	NB 38 18 00 00 M12 NI E1	NG.3	Ø37.8	M12	17.9	24	0.15 kg

## INFO

### Retractable nipple fastening versions

#### Version A\*

Simple nipple fastening from one side. For applications where nipple bores are not possible or permissible on the surface (e.g. top of the pallet) or for direct workpiece clamping.

STARK.classic.1\*

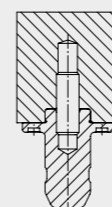

STARK.classic.2  
STARK.classic.3

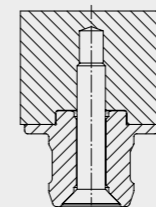

#### Version B

Simple nipple fastening from above.

STARK.classic.1

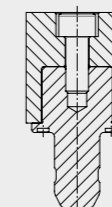

STARK.classic.2  
STARK.classic.3

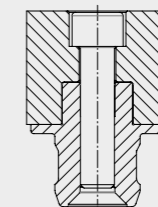

#### Version C\*

Ideal fastening version for clamping in laterally inverted manufacturing. Highest level of accuracy is guaranteed because the retractable nipples are fastened in the same locating bore.

STARK.classic.1\*

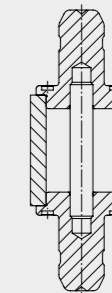

STARK.classic.2  
STARK.classic.3

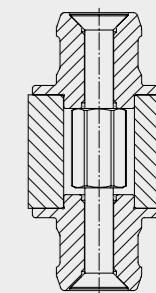

#### Version D

The fitting bores for the retractable nipple and all necessary positioning bores on the pallet can be produced in one operation. This results in the highest level of accuracy of the positions to each other. Mounting version D is additionally sealed by an O-ring.

STARK.classic.1

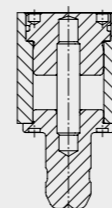

STARK.classic.2  
STARK.classic.3

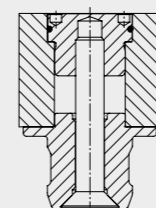

#### Version E

STARK.classic.1

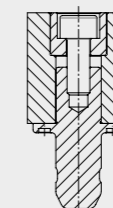

#### Version E.1

STARK.classic.2  
STARK.classic.3

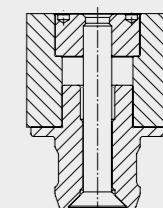

\* For the STARK.classic.1 with compensation (AG) retractable nipple, fastening version A is not possible and for version C only possible on one side.

### Key for nipple fastening



For assembly and disassembly of the STARK.classic.1 retractable nipple and of retractable nipple according to fastening versions "D & E.1"

- Width across flats SW22
- For tightening torque, see retractable nipple installation data sheets

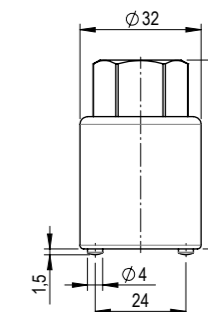

Z\_S804-254\_00

Order number	Article designation	Dimensions	Weight
S804-254	Key for nipple fastening M10	Ø32 mm / 50 mm	0.16 kg

### Spacer with O-ring - NG.1



For height compensation and for sealing the centre bore for STARK.classic.NG.1 Twister

- Very precise seat check (up to 0.01 mm) possible, as air can only escape at the 4 support islands due to the sealing of the centre bore.
- Installation acc. to Data Sheet D033

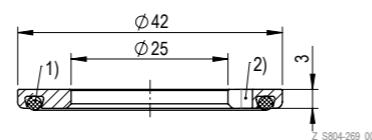

1) O-ring Ø 34,0 x 2,5 mm; S933-196-03  
2) Insealing slot

Order number	Article designation	Area of application/special feature	Weight
S804-269	DS 042 25 030 B	NG.1 Twister	0.02 kg

### Spacer with O-ring - NG.2/NG.3



For height compensation and for sealing the centre bore for STARK.classic.NG.2 Twister and STARK.classic.NG.3 Twister

- Very precise seat check (up to 0.01 mm) possible, as air can only escape at the 4 support islands due to the sealing of the centre bore.
- Installation acc. to Data Sheet D033

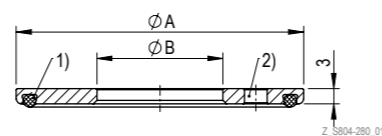

1) Sealing ring S933-231-01 (NG.2) / S933-439 (NG.3)  
2) Insealing bore

Order number	Article designation	Area of application/special feature	A	B	Weight
S804-280	DS 057 25 030 B	NG.2 Twister	57 mm	25 mm	0.05 kg
S804-060	DS 078 32 030 B	NG.3 Twister	77 mm	32 mm	0.09 kg

### Support disc made of hardened steel - NG.1



For use with non-hardened machine pallet surfaces for STARK.classic.NG.1 Twister and Tornado

- High wear resistance for non-hardened machine pallet surfaces
- Installation acc. to Data Sheet D033 (Sheet 5)

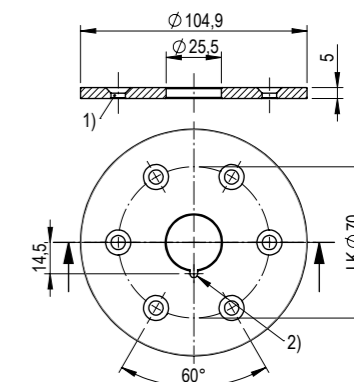

1) Countersink for M5 screw  
2) Insealing slot for Ø2.5 DIN 1481 / ISO 8752 clamping pin

Order number	Article designation	Area of application/special feature	Collar	Weight
S804-510-1	AS D105 25 50 A	NG.1 Twister & Tornado	Ø25	0.31 kg

### Support disc made of hardened steel - NG.2



For use with non-hardened machine pallet surfaces for STARK.classic.NG.2 Twister and Tornado

- High wear resistance for non-hardened machine pallet surfaces
- Installation acc. to Data Sheet D033 (Sheet 33)

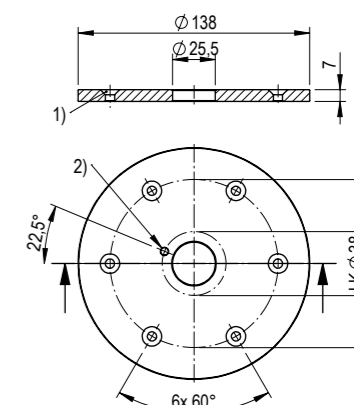

1) Countersink for M5 screw  
2) Insealing bore for M4 DIN 427 / ISO 2342 shaft screw

Order number	Article designation	Area of application/special feature	Collar	Weight
S804-281-02	AS D138 25 70 A	NG.2 Twister	Ø25	0.78 kg
S804-282	AS D138 25 70 A IX	NG-S with 4 grooves	Ø25	0.78 kg

### Support disc made of hardened steel - NG.3



For use with non-hardened machine pallet surfaces for STARK.classic.NG3 Twister and Tornado

- High wear resistance for non-hardened machine pallet surfaces
- Installation acc. to Data Sheet D033 (Sheet 10)

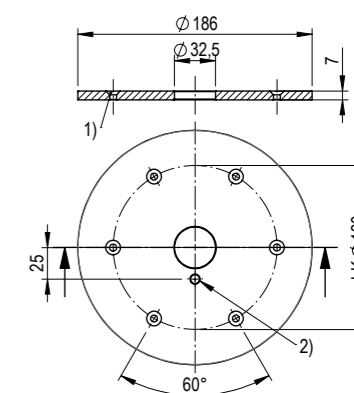

1) Countersink for M5 screw  
2) Insealing bore for M5 DIN 427 / ISO 2342 shaft screw

Order number	Article designation	Area of application/special feature	Collar	Weight
S03643	AS D186 32 70 A	NG.3 Twister & Tornado	Ø32	1.42 kg

#### INFO Spacer and support disc

Application example; STARK.classic.NG.2 Twister with spacer and support disc

- Nipple fastening
- Fixing screw for retractable nipple
- Fixing screw for hardened support disc
- Hardened support disc
- Spacer with O-ring (only necessary with Twister)
- Retractable nipple
- STARK.classic.NG.2 Twister

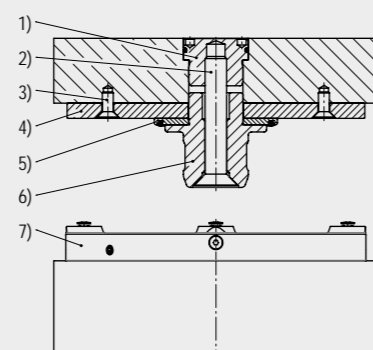

## PRESSURE BOOSTER

### RECORD pressure booster



Pressure booster is used to release single-acting clamping systems. The RECORD converts air pressure into the required hydraulic system pressure for releasing the STARK.classic.NG clamping elements.

- Air pressure 6 bar
- Oil volume 0.3l
- Max. oil pressure 40 bar

► Pressure booster can be extended to DH with article S804-427

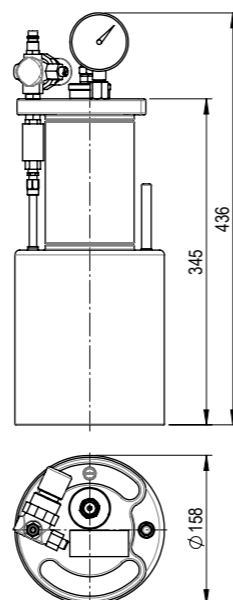

Z\_S804-412\_00

Order number	Article designation	Max. activation NG.1	Max. activation NG.2	Max. activation NG.3	Weight
S804-411	"Record" pressure booster 40 bar	14 elements	7 elements	2 elements	8.8 kg

### COMFORT pressure booster



Pressure booster is used to release single-acting clamping systems. The booster converts compressed air into hydraulic pressure and is suitable for application areas of 80 bar.

- Air pressure 6 bar
- Oil volume 1l
- Max. oil pressure 40 bar

► Pressure booster can be extended to DH with article S804-427

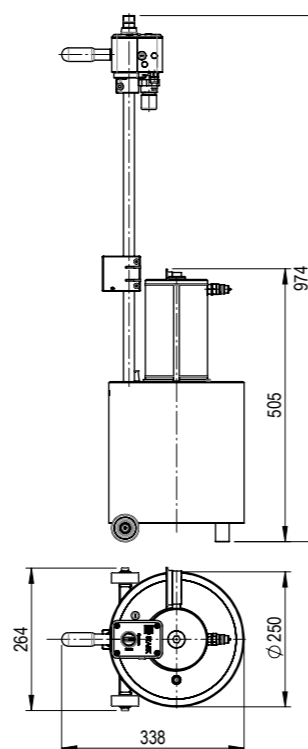

Z\_S804-433\_00

Order number	Article designation	Max. activation NG.1	Max. activation NG.2	Max. activation NG.3	Weight
S804-432	"COMFORT" booster 40bar	45 elements	24 elements	7 elements	27.30kg

### Hydraulic hose with couplings



Hydraulic hose with hydraulic plug-in coupling on both sides

Used to connect between pressure booster and fast closing clamp plate or surface-mounted element

- Max. pressure 300 bar

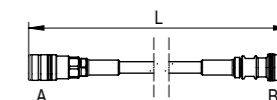

Z\_S704-153\_00

Order number	Article designation	Couplings A/B	Length L	Weight
S704-150	Hydraulic hose set	A/B: Standard (S952-044)	1.5 m	0.63 kg
S704-151	Hydraulic hose set	A: Leakage oil-free (S952-177) / B: Standard (S952-044)	1.5 m	0.63 kg
S704-152	Hydraulic hose set	A/B: Standard (S952-044)	3.0 m	0.85 kg
S704-153	Hydraulic hose set	A: Leakage oil-free (S952-177) / B: Standard (S952-044)	3.0 m	0.85 kg

### Pedal controller



Pedal controller for controlling the pressure booster

- Control of the pressure booster via foot controller
- The pressure booster does not have to be located in the immediate vicinity
- Both hands are free for loading or for removing the workpieces to be processed

Order number	Article designation	Weight
S804-419	Pedal controller for pressure booster (incl. pneumatic hose and screw-in connections)	1.5 kg

### DH pedal controller (third hand function)



The special pressure control (actuation) of the fast closing clamps allows the workpiece, pallet or device to be easily engaged. Feed, engage and clamp.

- For a vertical clamping position or for feeding by robots or handling systems

Order number	Article designation	Weight
S804-427	Pedal controller for pressure booster (incl. pneumatic hose and screw-in connections)	4 kg

## Air-hydraulic clamping pump



Air-hydraulic pump (40 bar)  
Actuation via integrated foot pedal  
Oscillating air/oil pressure intensifier

- Pneumatic coupling plug
- Pressure gauge (0-60 bar)
- Oil volume 2.4l
- Hydraulic hose set S952-138 leakage oil-free
- Operating manual WM-020-410-xx

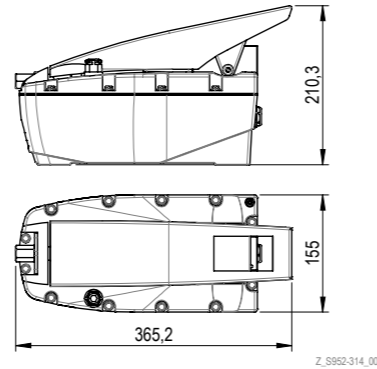

Order number	Article designation
S803-413	Air-hydraulic pump 40 bar with pressure gauge

## Hydraulic pump unit



Hydraulic pump unit optionally with DH (third-hand function) and query of the clamp control

- Ready for connection
- Energy-saving switch-off mode
- Volume flow 0.82/2.1/3.5l/min
- Max. operating pressure 500/250/160 bar

Suitable units are selected project-related from the extensive ROEMHELD unit product range.

Reference
ROEMHELD unit product range D 8.0115 (www.roemheld-gruppe.de)

## Third-hand function (DH) - the option for your process reliability

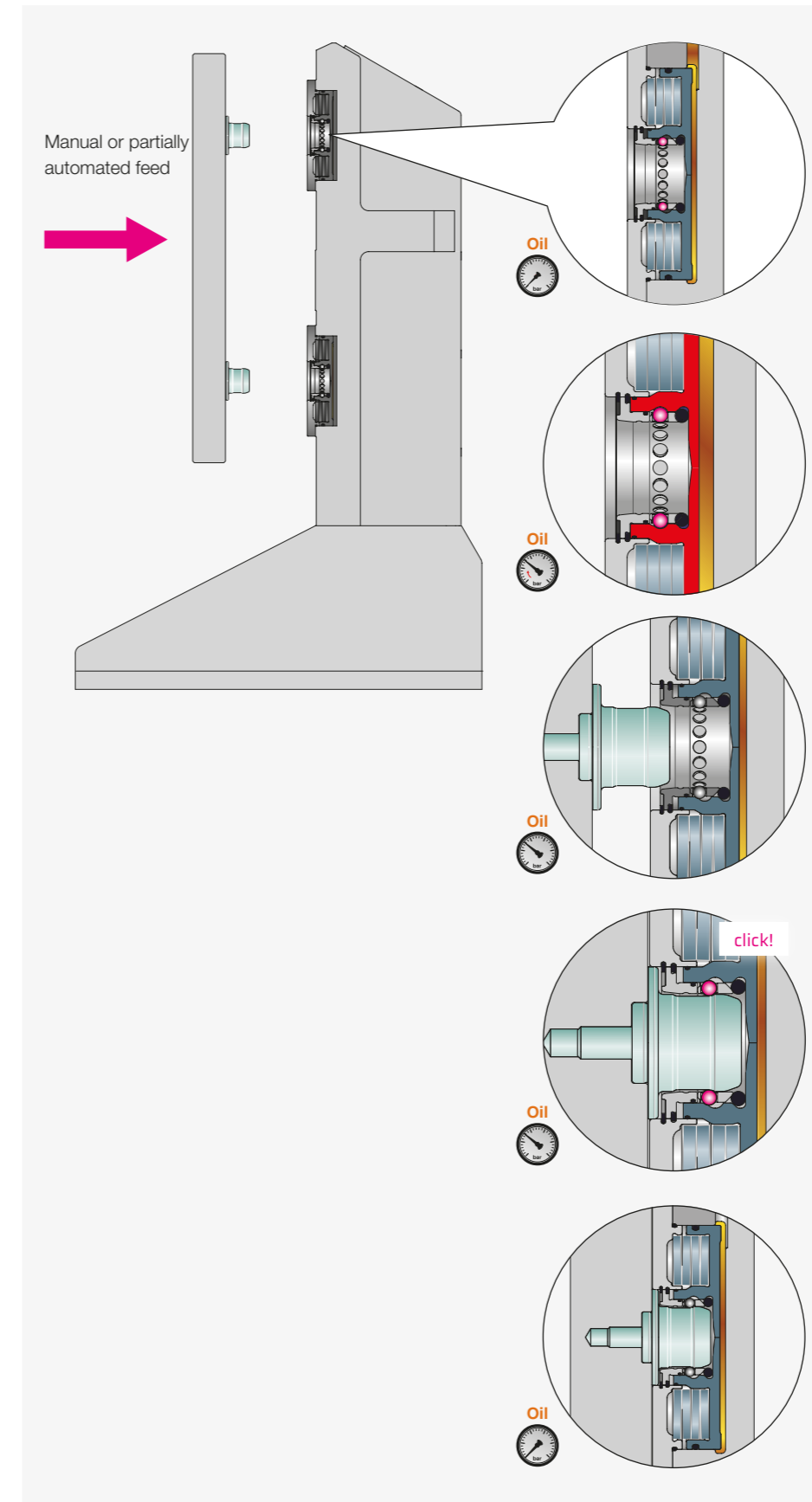

### THIRD-HAND FUNCTION

Schematic diagram for all STARK elements with third-hand function (DH).

### HOLDING FUNCTION

The fast closing clamp is applied with the holding pressure and is ready for the secure engagement of the pallet.

### FEEDING

The pallet is fed by hand or by crane.

### ENGAGING

The retractable nipples are retracted, engaged and then mechanically secured. You can release the pallet.

### POSITIONING AND CLAMPING

The fast closing clamp is switched without pressure. The pallet is now positioned, inserted and securely clamped via the cup springs.

## MEDIA DUCTS

Media ducts are used to feed media such as oil, air, water, etc. through the STARK.classic.NG zero point clamping system. This allows, for example, clamping fixtures mounted on machine pallets to be supplied with energy (hydraulic oil, compressed air). Media ducts each consist of two components: one for installation in the clamping element and one for installation in the pallet, which are automatically coupled when the retractable nipples are clamped.



### BENEFITS

- Media ducts can be integrated directly into the STARK.classic.NG zero point clamping system.
- Up to 4 media ducts are possible per clamping element.
- The coupling travel is matched with the retraction path of the clamping elements.

### TECHNICAL DATA

Min. coupling force	Operating pressure	Flow rate
250N/coupling	Max. 200bar	28l/min with dynamic pressure 90bar for HLP 46

### CALCULATION FORMULA

$$\text{Coupling force } F \text{ [N]} = (250 + 7.1 \times p \text{ [bar]}) \times n$$

(n = number of lines under the same pressure in the coupled state)

- Non-pressurised lines are under 250N spring force.
- The sum of the axial forces of the media ducts counteract the insertion force of the clamping elements.
- The machining force and the coupling force to be absorbed must not exceed the insertion force of the zero point clamping system!

#### Calculation example:

STARK.classic.NG.2 insertion force: 22,000N

Number of elements: 4 pcs.

Media duct pressure: 140bar

Number of media ducts: 4 pcs.

$$\text{Coupling force } F \text{ [N]} = (250 + 7.1 \times 140 \text{ [bar]}) \times 4 = 4,976 \text{ N}$$

$$\text{Element insertion force: } 4 \times 22,000 \text{ N} = 88,000 \text{ N}$$

$$88,000 \text{ N} > 4,976 \text{ N}$$

The calculation example shows that there is sufficient insertion force for machining. Media ducts must be taken into account in the tilting moment calculation, page 11.

## Determination of the coupling force

### INFO

Diagram for determining the coupling force per media duct

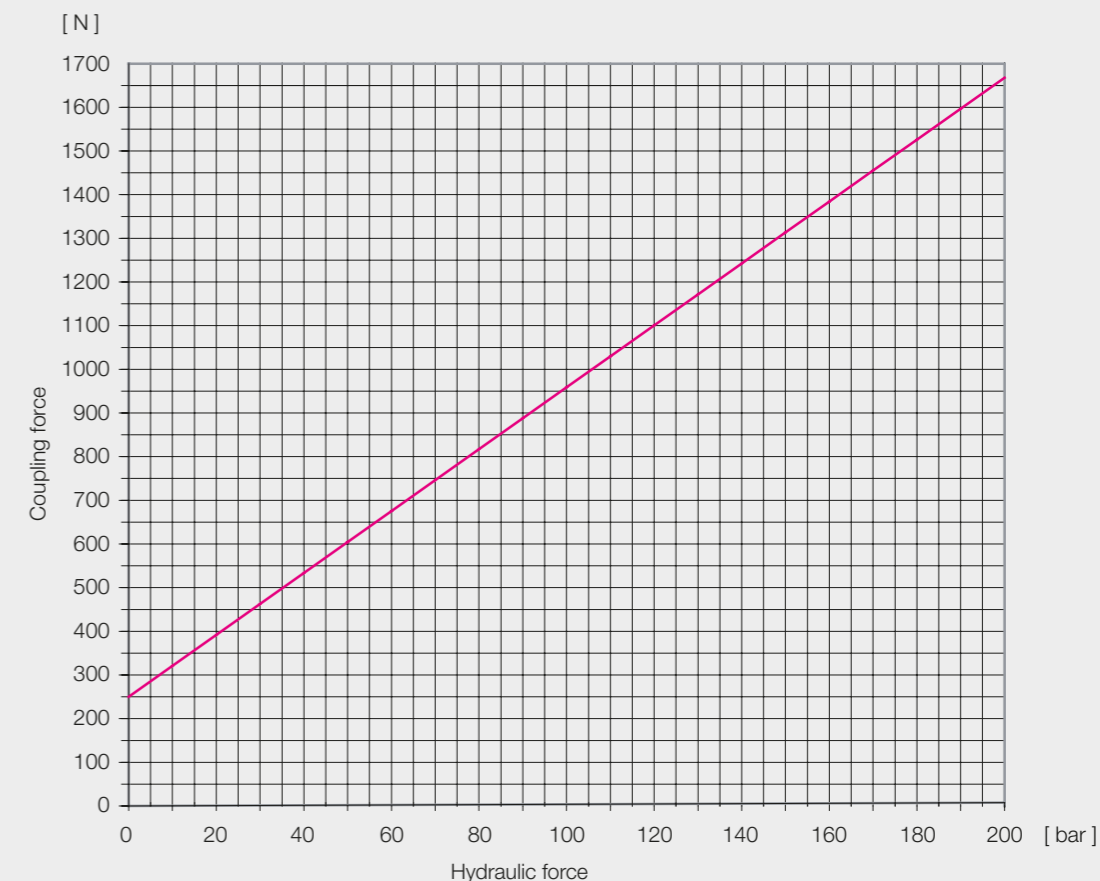

#### Important note for the correct use of the media ducts

- The media ducts may only be coupled without pressure.
- Machine pallets with regularly installed media ducts must not be pressurised when uncoupled. Fast closing plates with irregularly installed media ducts must also not be pressurised when uncoupled.
- Concentric pre-positioning of  $\varnothing 0.2 \text{ mm}$  is necessary.
- Both components of the media duct are closed when uncoupled.

### Media duct NW4 coupling mechanism ABV



Media duct for hydraulic oil, water and air, other media on request

The media duct is coupled by the retraction stroke of the clamping elements and is tight when uncoupled.

Together with the clamping element, the necessary positioning is ensured.

For direct installation in clamping elements as well as single or multiple couplings with or without blow-out.

- Screw-on version (ABV)
- Installation on the fast closing clamp side (regular)
- Weight 0.03 kg
- Installation acc. to Data Sheet D023

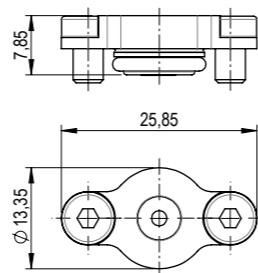

Z\_S704-200\_00

Order number	Article designation	Max. coupling force
S704-200	Media duct NW4 coupling mechanism ABV	See Determination of the Coupling Force (beginning of chapter)

### Media duct NW4 coupling nipple EKV



Media duct for hydraulic oil, water and air, other media on request

The media duct is coupled by the retraction stroke of the clamping elements and is tight when uncoupled.

For two-part installation in machine pallets as well as single or multiple couplings with or without blow-out, e.g. combined with hardened support disc.

- Plug-in version (EKV)
- Installation on the pallet side (regular)
- Weight 0.02 kg
- Installation acc. to Data Sheet D121

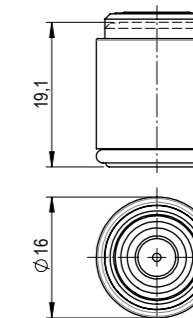

Z\_S704-203\_00

Order number	Article designation	Max. coupling force
S704-203	Media duct NW4 coupling nipple EKV	See Determination of the Coupling Force (beginning of chapter)

### Media duct NW4 coupling nipple ABV



Media duct for hydraulic oil, water and air, other media on request

The media duct is coupled by the retraction stroke of the clamping elements and is tight when uncoupled.

For direct installation in machine pallets as well as single or multiple couplings with or without blow-out.

- Screw-on version (ABV)
- Installation on the pallet side (regular)
- Weight 0.03 kg
- Installation acc. to Data Sheet D025

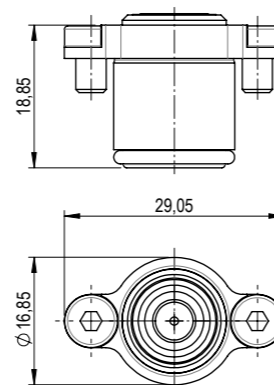

Z\_S704-201\_00

Order number	Article designation	Max. coupling force
S704-201	Media duct NW4 coupling nipple ABV	See Determination of the Coupling Force (beginning of chapter)

#### INFO Application example for screw-on version (ABV)

- 1 Fixing screws
- 2 Media duct, pallet side
- 3 Media duct, element side

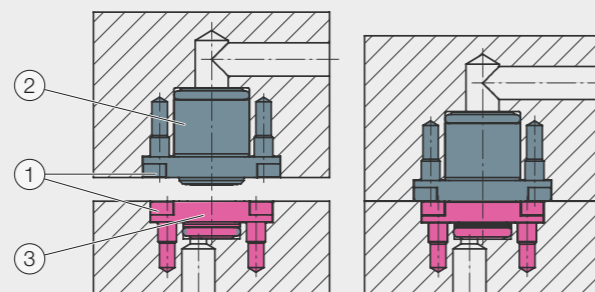

#### INFO Application example for plug-in version (EKV)

- 1 Fixing screws
- 2 Media duct, pallet side
- 3 Media duct, element side
- 4 Support disc

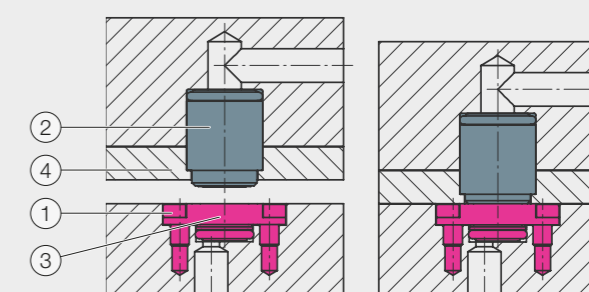

## Multiple coupling NW4 coupling mechanism



Media duct with 1-5 connections and integrated blow-out

- For controlling fixtures or hydraulic vices on machine pallets
- Particularly suitable for automated loading due to integrated blow-out
- Retrofitting existing zero point clamping systems with media ducts
- Installation on the fast closing clamp side (regular)
- Installation acc. to Data Sheet D042

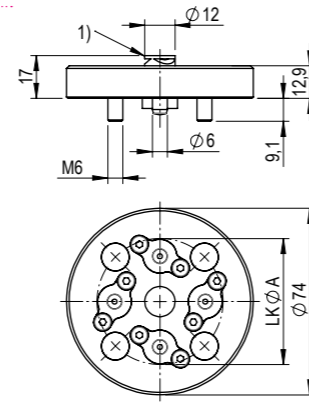

Z\_S703-011\_00

- 1) Blow-off nozzle
- Cylinder screws with hexagon socket M6x14mm S831-137, enclosed separately
- Screw covers M6 S899-408, enclosed separately
- O-rings Ø6x1.5mm S833-283, enclosed separately
- Cylinder pins Ø6 x 16 DIN 7979 D S836-111, enclosed separately

Order number	Article designation	Number of media ducts	LK ØA	Weight
S703-009	Multiple coupling NW4 coupling mechanism with 1× MD	1× media duct	50mm	0.5kg
S703-010	Multiple coupling NW4 coupling mechanism with 2× MD	2× media duct	50mm	0.5kg
S703-012	Multiple coupling NW4 coupling mechanism with 3× MD	3× media duct	50mm	0.5kg
S703-011	Multiple coupling NW4 coupling mechanism with 4× MD	4× media duct	50mm	0.5kg
S703-022	Multiple coupling NW4 coupling mechanism with 5× MD	5× media duct	54mm	0.5kg

## Multiple coupling NW4 coupling nipple



Media duct with 1-5 connections

- For controlling fixtures or hydraulic vices on machine pallets
- Particularly suitable for automated loading due to integrated blow-out
- Retrofitting existing zero point clamping systems with media ducts
- Installation on the pallet side (regular)
- Installation acc. to Data Sheet D040

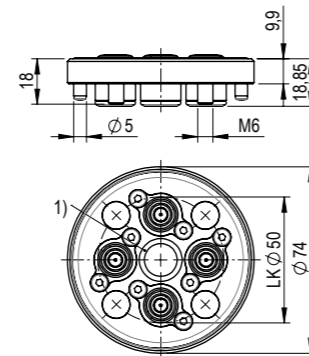

Z\_S703-016\_00

- 1) Thread M14x1
- Cylinder screws with hexagon socket M6 x 10mm S831-252, enclosed separately
- Screw covers M6 S899-408, enclosed separately
- Cylinder pins Ø5 x 12 DIN 7979 D S836-131, enclosed separately

Order number	Article designation	Number of media ducts	Weight
S703-014	Multiple coupling NW4 coupling nipple with 1× MD	1× media duct	0.5kg
S703-015	Multiple coupling NW4 coupling nipple with 2× MD	2× media duct	0.5kg
S703-017	Multiple coupling NW4 coupling nipple with 3× MD	3× media duct	0.5kg
S703-016	Multiple coupling NW4 coupling nipple with 4× MD	4× media duct	0.5kg
S703-023	Multiple coupling NW4 coupling nipple with 5× MD	5× media duct	0.5kg

## Application example - multiple coupling

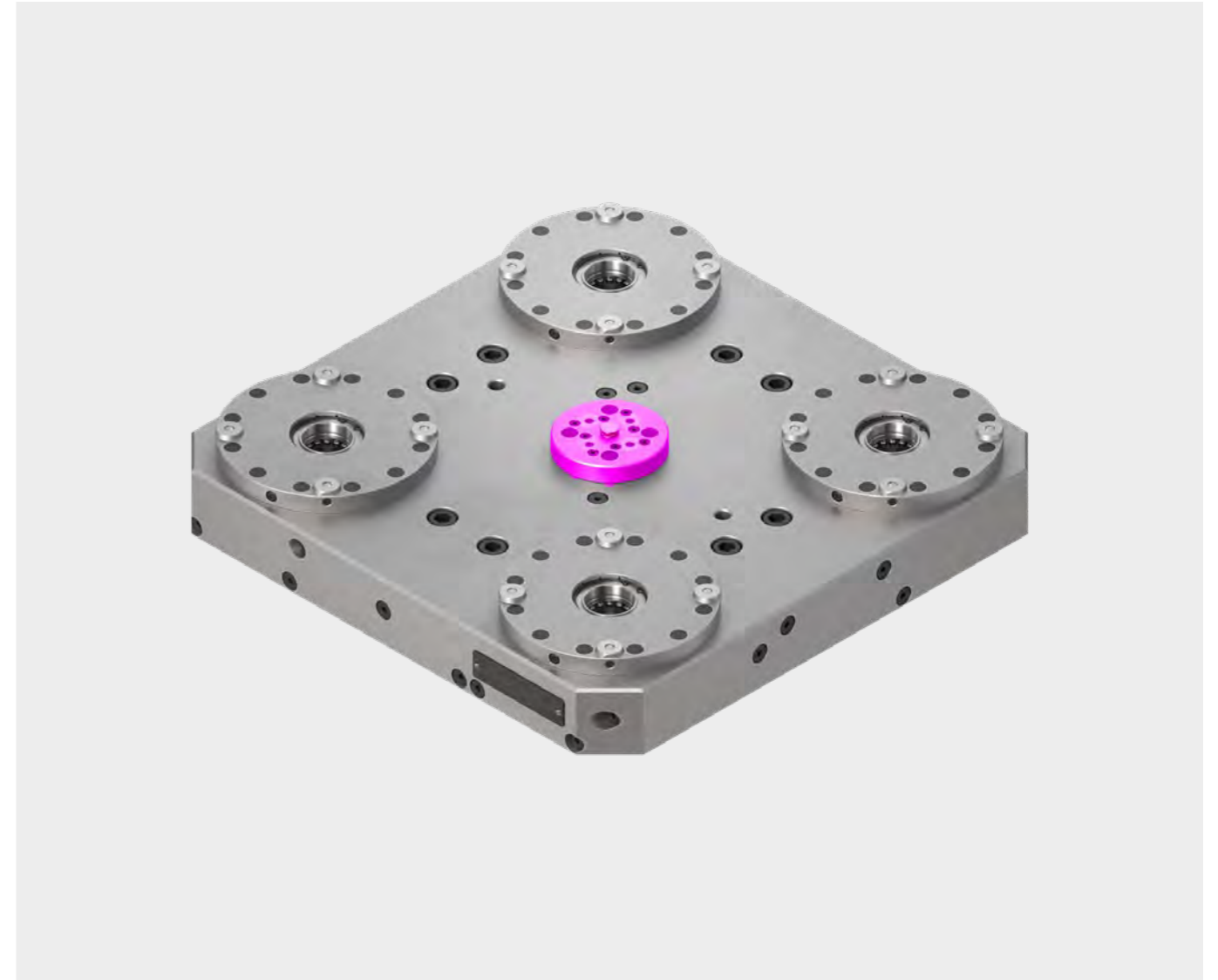

### Typical application for milling machines

- Zero point clamping system with 4 STARK.classic.NG.2 Twister elements
- Multiple coupling with 4 connections
- Integrated blow-out

### System options and features

- Customer-specific design
- 2 Pneumatic circuits for queries on the device
- 2 Hydraulic circuits for actuating the hydraulic device

## Blanking plug coupling mechanism ABV



Blanking plug for media ducts. To close the media ducts that are not required

- Suitable for S704-200

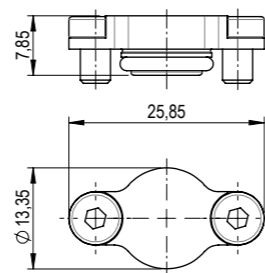

Z\_S704-208\_00

Order number	Article designation	Weight
S704-208	Blanking plug coupling mechanism ABV	0.01 kg

## Blanking plug coupling nipple EKV



Blanking plug for media ducts. To close the media ducts that are not required

- Suitable for S704-203

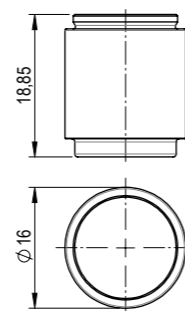

Z\_S704-260\_00

Order number	Article designation	Weight
S704-260	Blanking plug coupling nipple EKV	0.03 kg

## Disassembly pliers



Pliers for disassembling media ducts

Due to the adapted contour of the disassembly pliers, the media duct is not damaged during disassembly

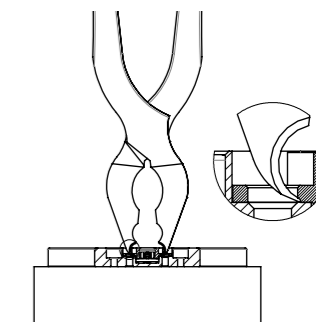

Z\_Anwendungsbeispiel\_Demontagezange\_MD\_00

Order number	Article designation	Weight
S504-015	Media duct disassembly pliers	0.18 kg

## Application example - Clamping tower with media duct

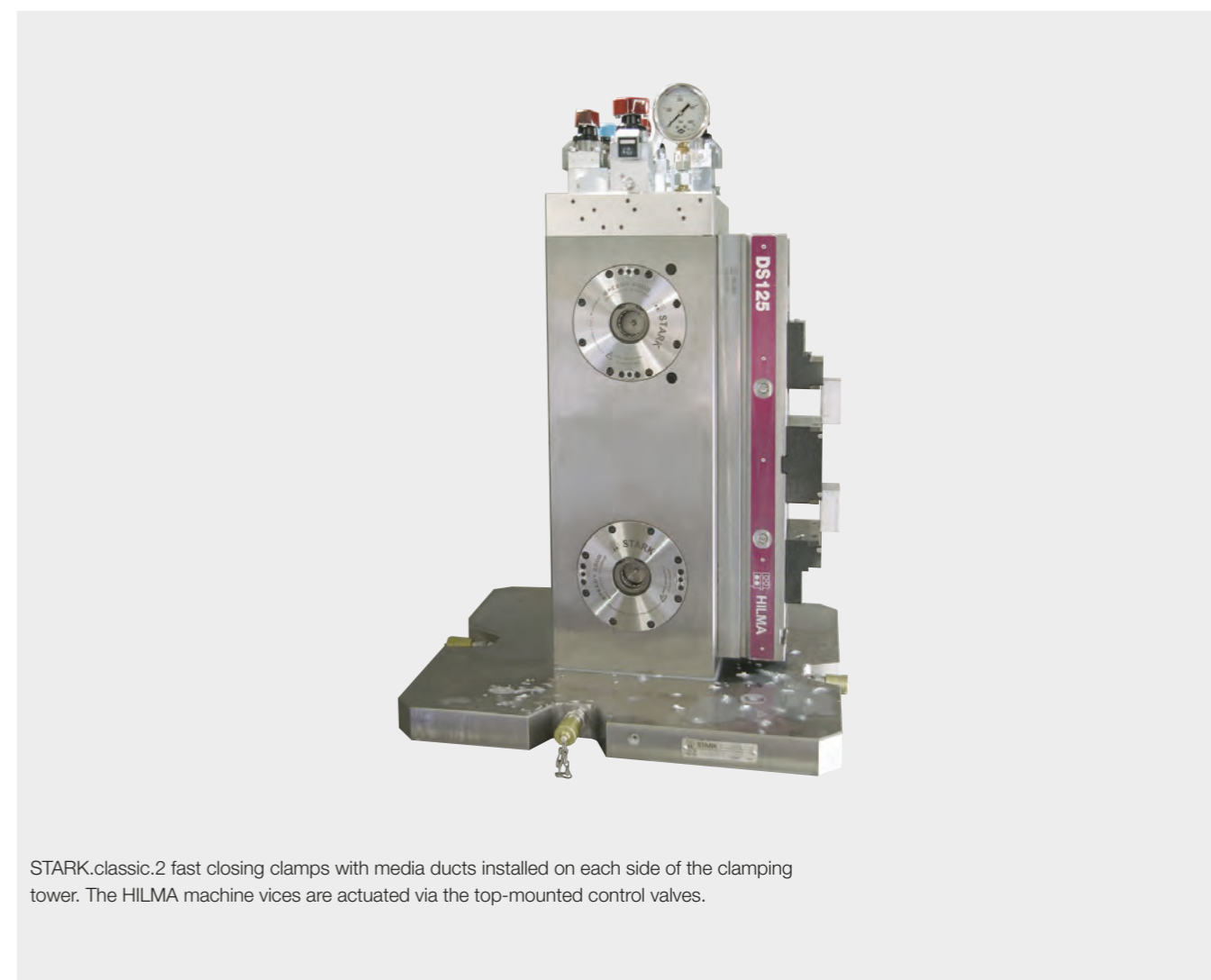

STARK.classic.2 fast closing clamps with media ducts installed on each side of the clamping tower. The HILMA machine vices are actuated via the top-mounted control valves.



## PRE-CENTRING

### Pre-centring bushes



Pre-centring is used for easier and gentler loading of pallets and fixtures. Recommended for large or heavy components.

- Material: Hardened tool steel
- Installation acc. to Data Sheet D128

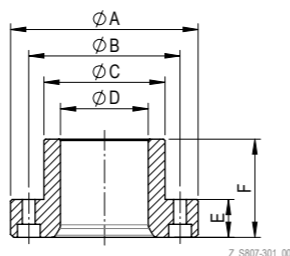

Order number	Article designation	ØA	ØB	ØC	ØD	E	F	Fastening	Weight
S807-301	Pre-centring bush Ø58 × 65 mm	124 mm	100 mm	80 mm	58 mm	25 mm	65 mm	4 × M8	2.5 kg
S807-304	Pre-centring bush Ø78 × 68 mm	144 mm	120 mm	100 mm	78 mm	28 mm	68 mm	4 × M8	3.35 kg
S807-308	Pre-centring bush Ø36 × 40 mm	71.9 mm	58 mm	45 mm	36 mm	18 mm	40 mm	4 × M6	0.5 kg
S807-310	Pre-centring bush Ø58 × 43 mm	114 mm	90 mm	74 mm	58 mm	17 mm	43 mm	4 × M8	1.3 kg

### Pre-centring mandrel



Pre-centring is used for easier and gentler loading of pallets and fixtures. Recommended for large or heavy components.

- Material: Hardened tool steel
- Installation acc. to Data Sheet D128

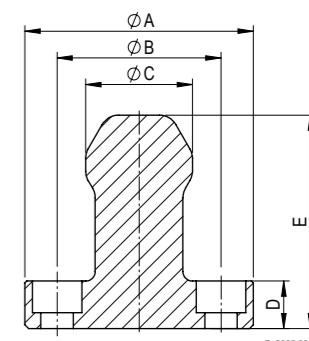

Order number	Article designation	ØA	ØB	ØC	D	E	Fastening	suitable for	Weight
S807-300	Pre-centring mandrel Ø56 × 105 mm	119.8 mm	86 mm	56 mm	25 mm	105 mm	4 × M16	S807-301	3 kg
S807-302	Pre-centring mandrel Ø56 × 112 mm	119.8 mm	86 mm	56 mm	25 mm	112 mm	4 × M16	S807-301	3.1 kg
S807-303	Pre-centring mandrel Ø76 × 112 mm	139.8 mm	105 mm	76 mm	25 mm	112 mm	4 × M16	S807-304	5.15 kg
S807-307	Pre-centring mandrel Ø34 × 59.5 mm	69.8 mm	51 mm	34 mm	25 mm	59.5 mm	4 × M8	S807-308	0.65 kg
S807-309	Pre-centring mandrel Ø56 × 65.5 mm	99.8 mm	76 mm	56 mm	15 mm	65.5 mm	6 × M8	S807-310	1.7 kg

### Pre-centring bush



Pre-centring is used for easier and gentler loading of pallets and fixtures. Recommended for large or heavy components.

- Material: Hardened steel
- Installation acc. to Data Sheet D128

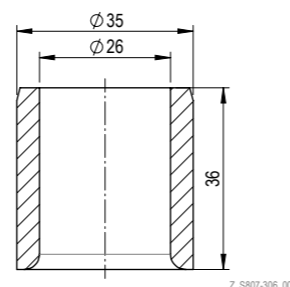

Order number	Article designation	Weight
S807-306	Pre-centring bush Ø26 × 36 mm	0.13 kg

### Pre-centring mandrel



Pre-centring is used for easier and gentler loading of pallets and fixtures. Recommended for large or heavy components.

- Material: Hardened tool steel
- Installation acc. to Data Sheet D128

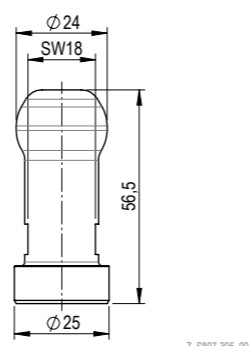

Order number	Article designation	Weight
S807-305	Pre-centring mandrel Ø24 × 56.5 mm	0.16 kg

### Application example - Pre-centring

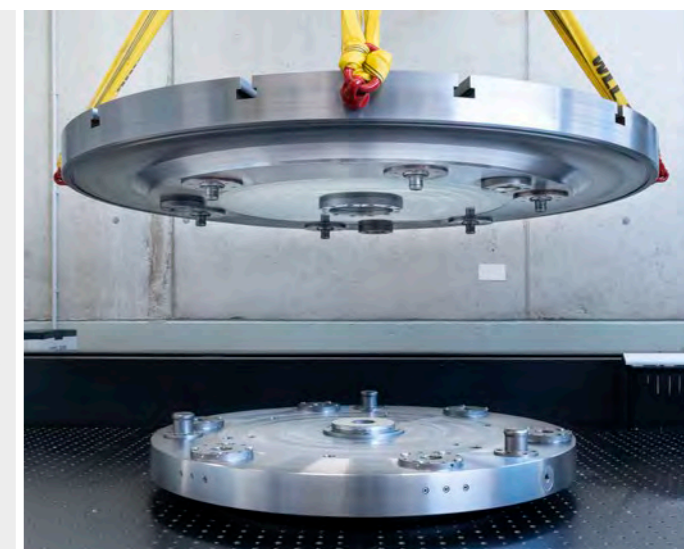
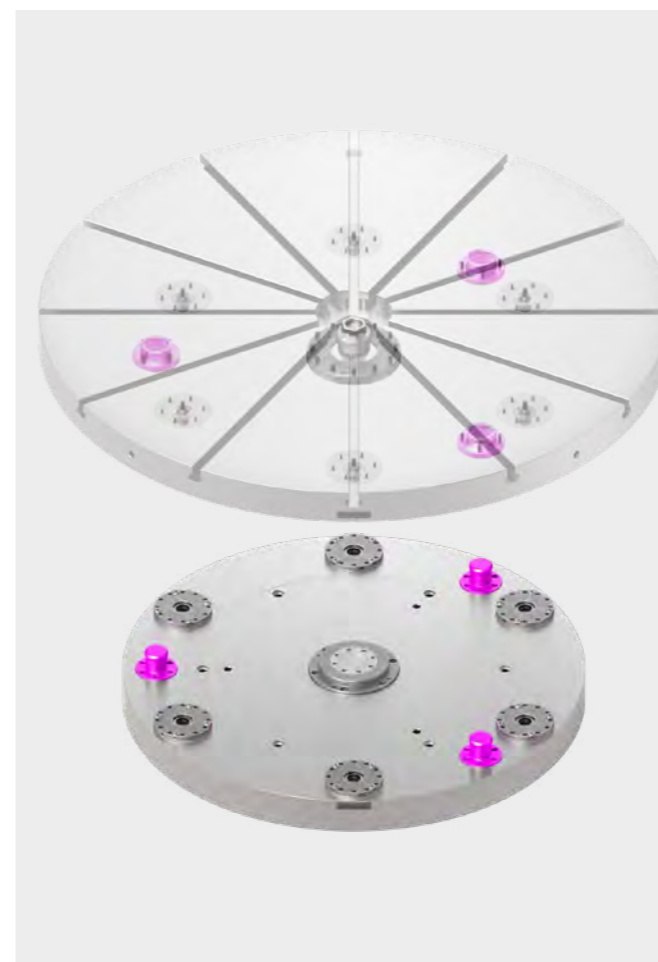

#### Grinding machine application Aviation

- Zero point clamping system with 6 STARK.classic.NG.2 elements
- 3 × pre-centring
- Centring elements with integrated media coupling
- Retractable nipple with spacer and support disc

## HYDRAULIC COUPLINGS

### Hydraulic plug-in coupling (oil leakage-free)



Oil leakage-free plug-in coupling for fast closing clamp plates or connection block for piping of the STARK.classic.NG fast closing clamps.

- Particularly recommended to use in conjunction with pressure boosters (no need to refill the pressure boosters).
- Use wherever leakage oil must not get into the drilling emulsion and for frequent coupling operations.
- Suitable for S952-177

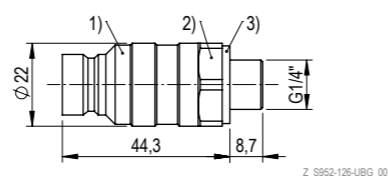

1) Coupling  
2) SW22  
3) Sealing disc

Order number	Article designation	max. pressure	Weight
S952-126-UBG	Oil-leakage-free hydraulic plug-in coupling	300 bar	0.10 kg

### Connection block with hydraulic plug-in coupling



Connection block for hydraulic piping for STARK.classic.NG fast closing clamps.

- Suitable for S952-177

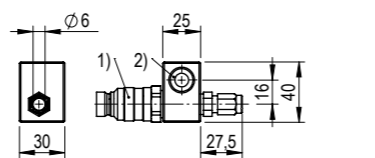

1) Hydraulic plug-in coupling S952-126  
2) Countersink for M6 DIN 912 / ISO 4762

Order number	Article designation	max. pressure	Weight
S804-180	Connection block for piping with oil leakage-free coupling	100 bar	0.20 kg

### Hydraulic plug-in coupling



Oil-leakage-free hydraulic plug-in coupling (hose side) for hydraulic piping for STARK.classic.NG clamping elements.

- Suitable for S952-126-UBG, S804-180

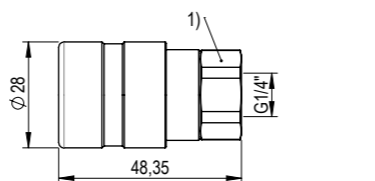

1) SW22

Order number	Article designation	max. pressure	Weight
S952-177	Oil leakage-free hydraulic plug-in coupling for piping, internal thread G1/4"	300 bar	0.10 kg

### Hydraulic plug-in coupling



Plug-in coupling for fast closing clamp plates or connection block for piping of the STARK.classic.NG fast closing clamps.

- Particularly recommended to use in conjunction with pressure boosters
- Use for frequent coupling operations.
- Suitable for S952-044

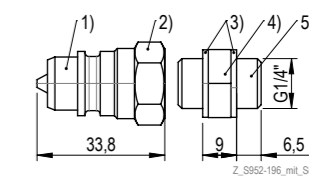

1) Hydraulic plug-in coupling S952-196  
2) SW 19 / 3) Sealing disc  
4) SW 16 / 5) Steel double nipple

Order number	Article designation	Thread	max. pressure	Weight
S804-371	Hydraulic plug-in coupling with sealing disc	G1/4" female thread	700 bar	0.10 kg
S952-196	Hydraulic plug-in coupling without sealing disc	G1/4" female thread	700 bar	0.04 kg
S804-372	Steel double nipple with 2 sealing discs	G1/4" male thread	500 bar	0.04 kg
S804-395	Aluminium protective cap			0.10 kg

### Connection block with hydraulic plug-in coupling



Connection block for hydraulic piping for STARK.classic.NG fast closing clamps.

- Suitable for S952-044

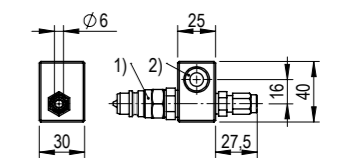

1) Hydraulic plug-in coupling S952-196  
2) Countersink for M6 DIN 912 / ISO 4762

Order number	Article designation	max. pressure	Weight
S804-370	Connection block for piping	100 bar	0.20 kg

### Hydraulic plug-in coupling



Hydraulic plug-in coupling (hose side) for hydraulic piping for STARK.classic.NG clamping elements.

- Suitable for S804-371, S804-370

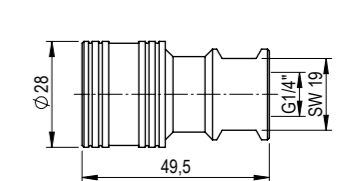

Z\_S952-044\_00

Order number	Article designation	max. pressure	Weight
S952-044	Hydraulic plug-in coupling for piping, internal thread G1/4"	300 bar	0.10 kg

## PNEUMATIC COUPLINGS

### Coupling nipple



Coupling nipple for STARK fast closing clamp plate

- For connection of pneumatic lines
- Suitable for S5000-300

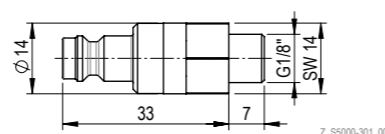

Order number	Article designation	Connection	Weight
S5000-301	Coupling nipple	G1/8"	0.05 kg

### Plug-in coupling



Pneumatic coupling (hose side) for connecting the STARK fast closing clamp plate

- Suitable for S5000-301

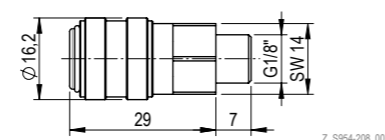

Order number	Article designation	Connection	Weight
S954-208	Plug-in coupling	G1/8"	0.05 kg

### Sliding coupling



Pneumatic coupling unit (hose side) with slide valve for connecting and operating the fast closing clamps

- Suitable for S5000-301

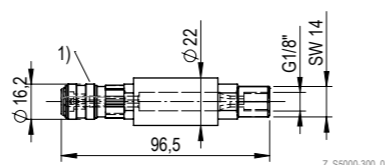

1) Coupling S954-208 suitable for coupling nipple S5000-301

Order number	Article designation	Connection	Weight
S5000-300	Sliding coupling	G1/8"	0.20 kg

## ACCESSORIES

### Clamp control valve installation aid



Installation aid for assembly and installation of the clamp control valve S704-210

- Operating manual clamp control valve WM-020-255-xx

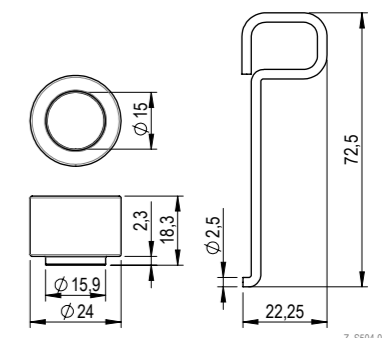

Order number	Article designation	Weight
S504-070	Clamp control valve installation aid	0.03 kg

### Positioning nipple



Positioning nipple for mounting in a collet chuck

- For fast and precise positioning of clamping elements

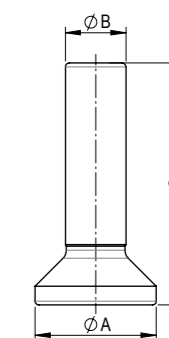

Order number	Article designation	Ø A	Ø B	Ø C
S804-259	Positioning nipple for STARK.classic.NG.1	32	16	64
S804-258	Positioning nipple for STARK.classic.NG.2	47	25	82
S804-260	Positioning nipple for STARK.classic.NG.3	65	32	100

### Sliding block with pin



Sliding blocks are used for positioning in the T-slots

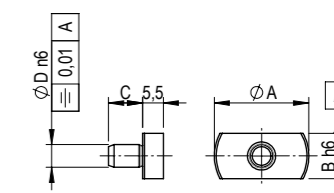

Order number	A	B	C	D
S704-160	25mm	12mm	9mm	6mm
S704-162	25mm	14mm	14mm	12mm
S704-163	30mm	18mm	20mm	16mm
S704-166	25mm	20mm	14mm	12mm

## Retractable nipple transport protection



Transport protection to prevent damage to the retractable nipples and pallet surfaces during transport or stacked storage.

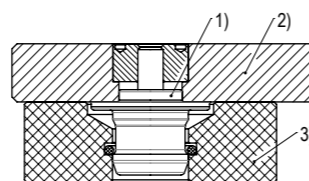

1) Retractable nipple  
2) Pallet  
3) Transport protection

Order number	Article designation	Weight
S704-130	Transport protection for STARK.classic.1 retractable nipple	0.35 kg
S704-133	Transport protection for STARK.classic.2 retractable nipple	0.35 kg
S704-131	Transport protection for STARK.classic.3 retractable nipple	0.45 kg

## Sealing plugs



Sealing plug with O-ring that prevents the penetration of dirt (e.g. chips).

Protection for unused fast closing clamps. Sealing plug (2) is pressed out of the clamping element by turning the screw (1) clockwise. Turn the spacer (3) back again before the next insertion.

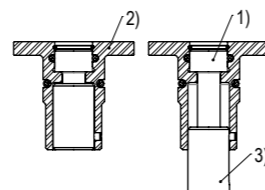

1) Screw  
2) Sealing plug  
3) Spacer

Order number	Article designation	Weight
S704-098	Sealing plug for STARK.classic.NG.1	0.04 kg
S704-099	Sealing plug for STARK.classic.NG.2	0.06 kg
S704-093	Sealing plug for STARK.classic.NG.3	0.14 kg

## Specification dimension tester



The specification dimension tester is used to check the specification dimension according to the operating manual of the respective element types.

The DH specification dimension tester is used to check the function of the clamping elements and to adjust the DH position (third-hand function).

- Supplied in a plastic case
- Operating Manual WM-020-349-xx-xx

Order number	Article designation
S504-021	Specification dimension tester for STARK.classic.NG.1
S504-031	Specification dimension tester DH for STARK.classic.NG.1
S504-022	Specification dimension tester for STARK.classic.NG.2
S504-032	Specification dimension tester DH for STARK.classic.NG.2
S504-023	Specification dimension tester for STARK.classic.NG.3
S504-033	Specification dimension tester DH for STARK.classic.NG.3

## Ball retainer assembly aid



The ball retainer assembly aid is used for easy assembly/disassembly of the ball retainers.

- Especially for vertical applications (e.g. clamping towers).

Order number	Article designation	Weight
S704-221-M	Ball retainer assembly aid for STARK.classic.NG.2	0.02 kg

## Mechanical insertion force tester



The insertion force tester is used to reliably check the insertion force of the STARK fast closing clamps.

The insertion force may change depending on actuation cycles and wear. As a result, the specified insertion force is no longer achieved and the machining forces are no longer fully absorbed by the zero point clamping system. As a preventive measure, STARK recommends regular inspection of the clamping elements (see operating manual).

Order number	Article designation	Weight
S504-001	Mechanical insertion force tester STARK.classic.1	6.2 kg
S504-002	Mechanical insertion force tester STARK.classic.2	7.1 kg
S504-004	Mechanical insertion force tester STARK.classic.3	8.6 kg
S504-000	Rental case: Mechanical insertion force tester STARK.classic.1/2/3	

### INFO

#### Mechanical insertion force tester



Supplied in a practical plastic case (L390 × W280 × H110)

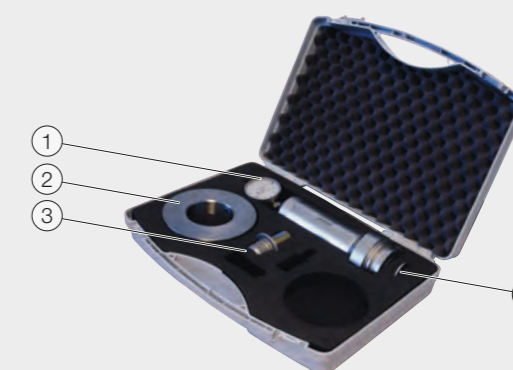

Insertion force tester (1) with calibration certificate and operating manual in the plastic box, with support ring (2), adapter retractable nipple (3) and spacer (4)

## O-rings service set

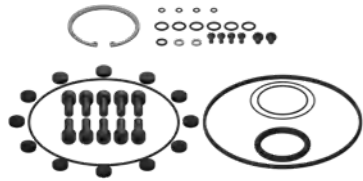

Service set consisting of all O-rings, screws, lock rings including special grease. For maintenance of the STARK.classic.NG clamping elements.

Order number	Article designation	Weight
S804-964	STARK.classic.NG.1 O-rings service set	0.1 kg
S804-199	STARK.classic.NG.2 O-rings service set	0.1 kg
S804-198	STARK.classic.NG.3 O-rings service set	0.1 kg

## Cup springs and O-rings service set

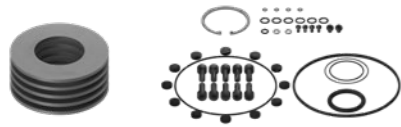

Service set consisting of cup springs and O-rings service set for maintenance of STARK.classic.NG clamping elements.

STARK recommends a regular check of the insertion force with the mechanical insertion force tester S504-000.

Order number	Article designation	Number of cup springs	incl. O-rings service set	Weight
S804-963	Cup spring set for STARK.classic.NG.1	5 pcs.	S804-964	0.4 kg
S804-957	Cup spring set for STARK.classic.NG.2	5 pcs.	S804-199	0.93 kg
S804-956	Cup spring set for STARK.classic.NG.3	5 pcs.	S804-198	1.94 kg

## Screw cover

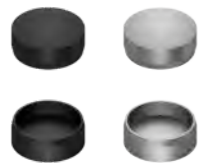

Screw cover suitable for the retractable nipples or fast closing clamps of the STARK.classic.NG family

Order number	Article designation	Size	Version	Weight
S704-231	Stainless steel screw cover for M6	NG.1	M6 Ø 11.5 × 3 mm	0.001 kg
S999-408	Plastic cover for M6	NG.2	M6 Ø 11 × 3.3 mm	0.001 kg
S999-365	Plastic cover for M8	NG.3	M8 Ø 15 × 4.2 mm	0.001 kg

## Hydraulic assembly aid



Hydraulic assembly aid consisting of knurled nut, assembly aid with connection for hand pump, expanding mandrel and centring shells.

- Disassembly/assembly of retaining ring and ball retainer, for use in any installation position, for quick and easy assembly
- Operating Manual WM-020-084-xx-xx

Order number	Article designation	Typical operating pressure	Weight
S504-011	Hydraulic assembly aid for STARK.classic.NG.1	90 bar	3.30 kg
S504-012	Hydraulic assembly aid for STARK.classic.NG.2	100 bar	3.75 kg
S504-013	Hydraulic assembly aid for STARK.classic.NG.3	150 bar	6.85 kg

## Hand pump



Hydraulic pump can supply two independent hydraulic circuits.

By means of a rotary slide and the handwheel, two circuits can be controlled individually or together.

In hydraulic double-acting systems, one side can be pressurised while the other side is relieved into the tank.

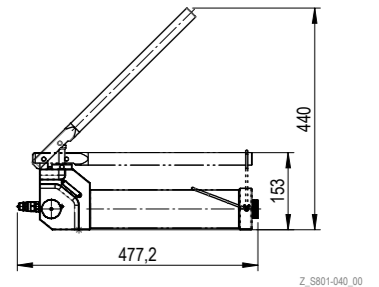

Order number	Article designation	System pressure	Oil volume	Weight
S801-040	Hand pump	0 - 250 bar	1 l	6.3 kg

## Assembly aid



Assembly aid consisting of centring bolt and two centring pins. For disassembly/assembly of cup springs and cover.

- Operating Manual WM-020-332-xx-xx

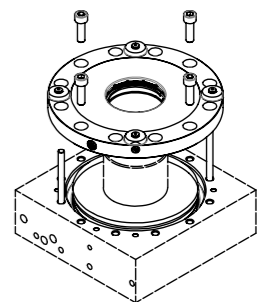

Order number	Article designation	Weight
S504-008-01	Centring aid for STARK.classic.NG.1	0.16 kg
S504-009	Centring aid for STARK.classic.NG.2	0.36 kg
S504-010-01	Centring aid for STARK.classic.NG.3	0.39 kg

Order number directory STARK.classic.NG

S02637	36	S801-040	73	S804-522	20	S804-638	20
S02637-01	36	S803-413	54	S804-522-P	18, 20	S804-639	20
S02637-02	37	S804-060	50	S804-523	20	S804-640	20
S02637-11	36	S804-180	66	S804-524	20	S804-641	20
S02942	36	S804-198	72	S804-525	12, 20	S804-642	20
S03384	36	S804-199	72	S804-526	12, 20	S804-643	20
S03385	36	S804-209	36	S804-527	12, 20	S804-644	20
S03386	37	S804-209HG	36	S804-528	12, 20	S804-645	20
S03641	40	S804-209K	36	S804-529	20	S804-645-P	18, 20
S03642	40	S804-211HG	36	S804-530	12, 20	S804-646	20
S03643	51	S804-213HG	36	S804-530-P	18, 20	S804-647	20
S03660	41	S804-230	36	S804-531	12, 20	S804-648	20
S04156	40	S804-230K	36	S804-532	20	S804-649	20
S5000-300	68	S804-238	37	S804-533	13, 20	S804-891	28
S5000-301	68	S804-238K	37	S804-533-P	18, 20	S804-892	28
S504-000	71	S804-250	48	S804-534	13, 20	S804-893	28
S504-001	71	S804-252	48	S804-535	13, 20	S804-956	72
S504-002	71	S804-254	49	S804-535-P	18, 20	S804-957	72
S504-004	71	S804-258	69	S804-536	13, 20	S804-963	72
S504-008-01	73	S804-259	69	S804-538	14, 21	S804-964	72
S504-009	73	S804-260	69	S804-538-02	14, 21	S804-965	29
S504-010-01	73	S804-262	48	S804-538-03	21	S804-966	29
S504-011	73	S804-264	48	S804-538-03-P	18, 21	S804-967	29
S504-012	73	S804-266	48	S804-538-P	18, 21	S806-024	14, 21
S504-013	73	S804-267	48	S804-539	21	S806-024-P	18, 21
S504-015	63	S804-269	50	S804-539-P	18, 21	S806-025	14, 21
S504-021	70	S804-280	50	S804-540-01	15, 21	S806-026	21
S504-022	70	S804-281-02	51	S804-540-02	15, 21	S806-027	21
S504-023	70	S804-282	51	S804-540-02-P	18, 21	S807-212	16, 21
S504-031	70	S804-290	40	S804-540-11	15, 21	S807-212-01	16, 21
S504-032	70	S804-290-01	40	S804-540-12	15, 21	S807-212-P	18, 21
S504-033	70	S804-290HG	40	S804-540-12-P	18, 21	S807-213	21
S504-037	70	S804-290K	40	S804-541	24	S807-213-P	18, 21
S504-038	70	S804-292	40	S804-541-P	24	S807-214	16, 21
S504-039	70	S804-292K	40	S804-545	14, 21	S807-215	16, 21
S504-041	70	S804-294	41	S804-546	14, 21	S807-216	16, 21
S504-070	69	S804-294K	41	S804-547	14, 21	S807-217	16, 21
S703-009	60	S804-312-01	40	S804-548	14, 21	S807-218	21
S703-010	60	S804-312K	40	S804-549	21	S807-219	21
S703-011	60	S804-313K	40	S804-550	21	S807-220	21
S703-012	60	S804-314K	41	S804-551	21	S807-221	21
S703-014	60	S804-370	67	S804-552	21	S807-222	21
S703-015	60	S804-371	67	S804-553	21	S807-222-P	18, 21
S703-016	60	S804-372	67	S804-554	21	S807-223	21
S703-017	60	S804-395	67	S804-555	21	S807-224	21
S703-022	60	S804-411	52	S804-556	21	S807-225	21
S703-023	60	S804-419	53	S804-557	21	S807-226	21
S704-093	70	S804-427	53	S804-558	21	S807-227	21
S704-098	70	S804-432	52	S804-559	21	S807-227-P	18, 21
S704-099	70	S804-469HG	38	S804-560	21	S807-228	21
S704-130	70	S804-470	38	S804-561	21	S807-229	21
S704-131	70	S804-470-02	38	S804-561-P	18, 21	S807-230	21
S704-133	70	S804-470HG	38	S804-562	21	S807-231	21
S704-150	53	S804-470K	38	S804-563	21	S807-300	65
S704-151	53	S804-471	38	S804-564	21	S807-301	64
S704-152	53	S804-471K	38	S804-565	21	S807-302	65
S704-153	53	S804-472	39	S804-575	16, 21	S807-303	65
S704-160	69	S804-472K	39	S804-575-P	18, 21	S807-304	64
S704-162	69	S804-474	38	S804-576	16, 21	S807-305	64
S704-163	69	S804-474-01	24	S804-577	21	S807-306	64
S704-166	69	S804-474-02	38	S804-578	21	S807-307	65
S704-200	58	S804-474HG	38	S804-580-01	17, 21	S807-308	64
S704-201	58	S804-474K	38	S804-580-02	17, 21	S807-309	65
S704-203	59	S804-476	38	S804-580-02-P	18, 21	S807-310	64
S704-208	62	S804-476K	38	S804-583	21	S952-044	67
S704-210	31	S804-478	39	S804-584	21	S952-126-UBG	66
S704-221-M	71	S804-478K	39	S804-590	47	S952-177	66
S704-231	72	S804-480	46	S804-591	47	S952-196	67
S704-260	62	S804-481	46	S804-592	47	S954-208	68
S704-296	31	S804-482	46	S804-634	20	S999-365	72
S801-009	45	S804-510-1	51	S804-634-P	18, 20	S999-408	72
S801-010	44	S804-520	12, 20	S804-635	20		
S801-011	44	S804-520-P	18, 20	S804-636	20		
S801-012	44	S804-521	12, 20	S804-637	20		

**INFO** NEW order numbers

In the course of a system modification within the ROEMHELD Group, the order numbers for STARK Spannsysteme have been adapted and standardised.

- NEW: all order numbers start with **S**
- NEW: Hyphen - instead of blank space

**S804-520**  
instead of  
804 520

**Examples**

NEW order number	OLD order number	Modifications
S02637	S02637	No modification
S804-520	804 520	<b>S</b> prefix, hyphen - instead of blank space

A COMPANY OF THE  
ROEMHELD GROUP

# STARK Spannsysteme

The ROEMHELD Group consists of 5 companies at locations in Germany and Austria, each with different products and orientations. With numerous subsidiaries, sales partners and service companies on all continents and in more than 50 countries, rapid and intensive customer support is provided in the mechanical engineering, medical technology, automotive, aviation and agricultural industries.

As part of the ROEMHELD Group, STARK benefits from the security and experience of a family-run traditional company as well as from the worldwide sales and service network. At the same time, this background provides the independence to pursue dynamic and innovative goals for new market-driven developments and customer-specific solutions with which STARK maintains its leading technological position.



**ROEMHELD**  
HILMA ■ STARK

## **STARK** Spannsysteme

A company of the ROEMHELD Group

STARK Spannsysteme GmbH  
Römergrund 14 | 6830 Rankweil  
Austria

Phone +43 5522 37 400-0  
Mail [info@stark-roemheld.com](mailto:info@stark-roemheld.com)

[stark-roemheld.com](http://stark-roemheld.com)