

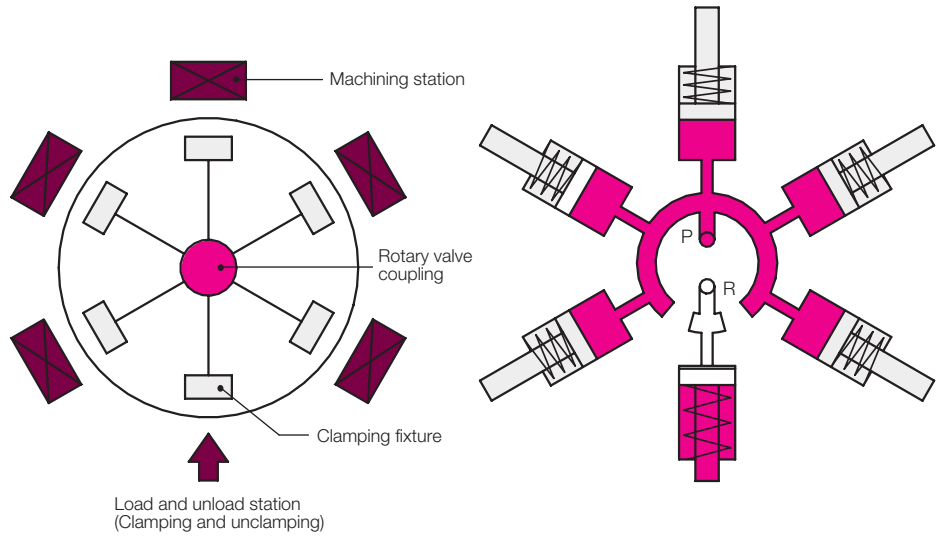

Pneumatic Rotary Valve Coupling
ND 3, max. operating pressure 10 bar



Description

Rotary couplings are generally made to transfer liquid or gaseous media from a stationary to a rotating component. Due to its design the rotary valve coupling permits additional control functions, so that valves and electrical control can be reduced to a minimum. These control functions are used in case of clock-pulse controlled rotary indexing tables. Station 1 of these elements is used as load and unload station (clamping and unclamping) and all additional stations are continuously pressurised or discharged to the pressure of the atmosphere. The transfer of the pressure medium in the control stations is made leakage-free.

Important notes

The materials of this rotary valve coupling allow the operation with oiled and unoled air. An adaptation is required in case of other media. The control function of the standard elements refers to one station. If other switching functions are required for a **special version**, please let us have your description with indication of operating pressure, temperature, media and speed i.e. cycle time.

Number of stations	5	6	7	8
Part-no. for single-acting cylinders	9295-601	9296-601	9297-601	9298-601
Part-no. for double-acting cylinders	9295-602	9296-602	9297-602	9298-602

For applications requiring 2, 3 and 4 station rotary valve couplings, use 6 and 8 station units with unused ports plugged off. Special versions are available on request.

Application example



The figure shows the application of four station rotary indexing machine. In three operating stations the workpieces are bored by multiple spindle heads and threads are cut. At the load and unload station the machined workpieces are exchanged with unmachined ones. The pneumatic clamping elements are double-acting. The control is designed according to the circuit example on the next page; however every second port is not used.

Rotary valve couplings for single-acting cylinders
9295-601 – 9298-601

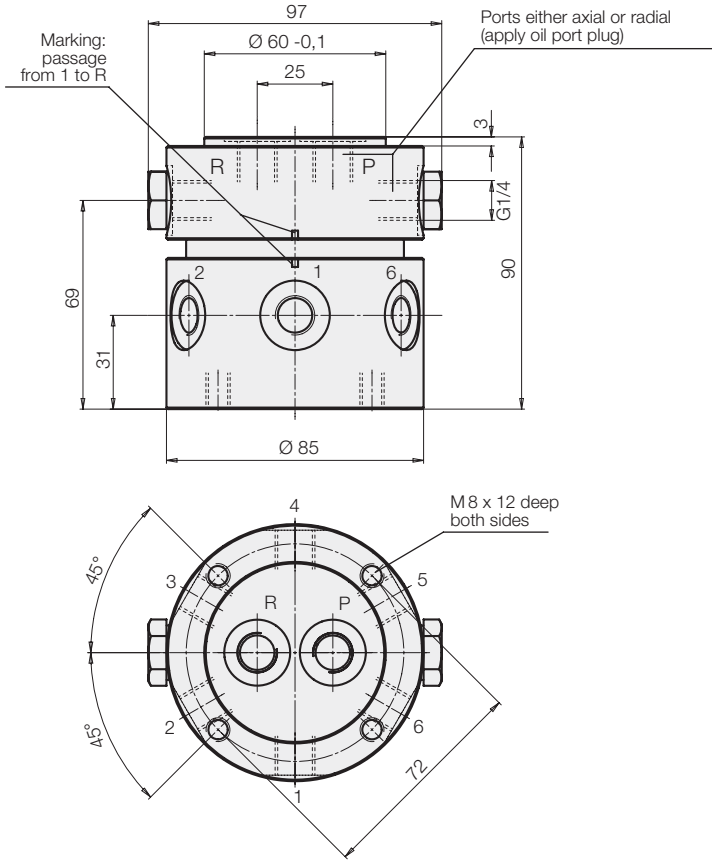

Circuit example

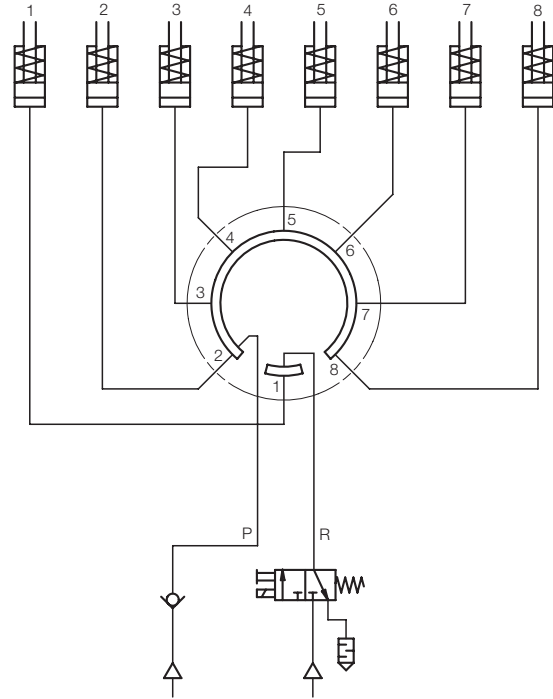

Rotary valve couplings for double-acting cylinders
9295-602 – 9298-602

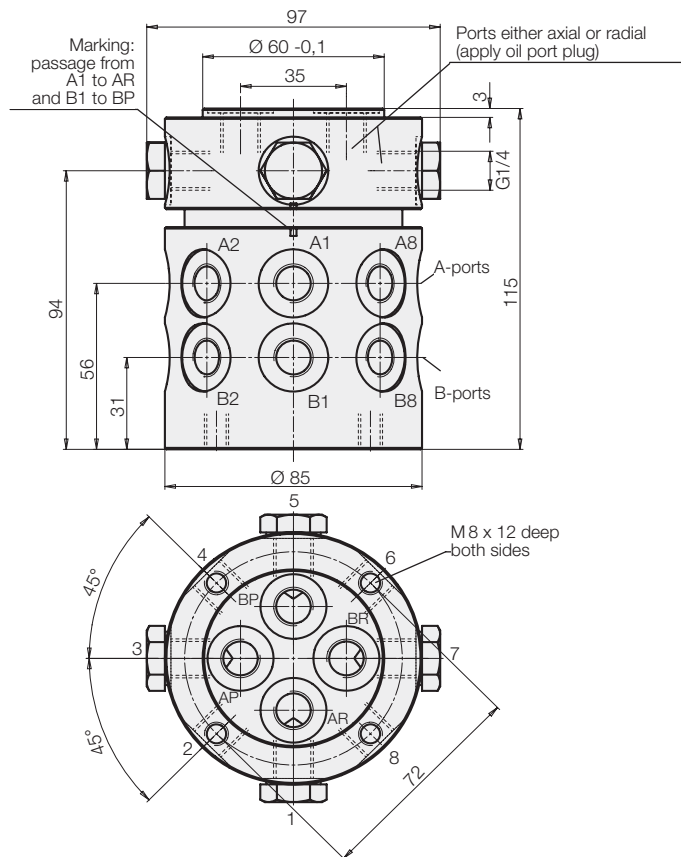

Circuit example

