

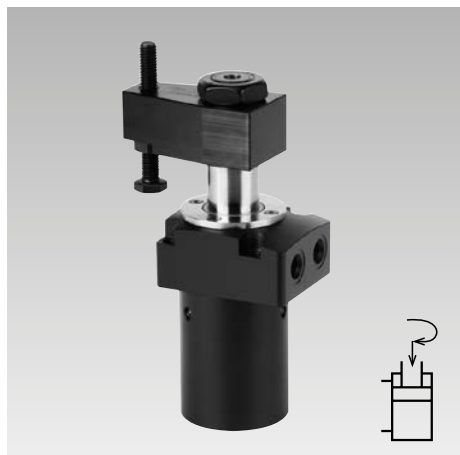

Swing Clamps with Sturdy Swing Mechanism

Top flange type, with optional position monitoring, double acting, max. operating pressure 70 bar



Advantages

- 4 sizes available
- Compact design partially recessible
- High clamping force already at 70 bar
- Sturdy swing mechanism
- Very short clamping time
- Insensitive against high flow rates
- Indexing of the clamping arm in a specified position is possible
- Special swing angle easily realizable
- FKM wiper standard
- Metallic wiper optional
- Throttle valves available as accessory
- Position monitoring available as accessory
- Mounting position: any

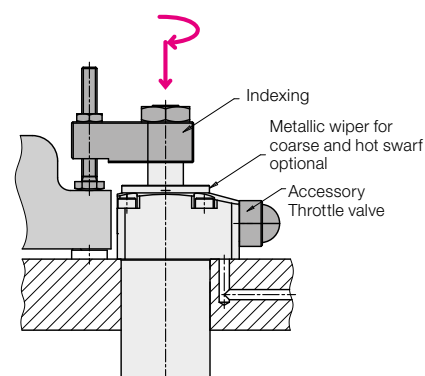

Application

Hydraulic swing clamps are used for clamping of workpieces, when it is essential to keep the clamping area free of straps and clamping components for unrestricted workpiece loading and unloading.

This series obtains very high clamping forces already at 70 bar and can directly be connected to the low-pressure hydraulics of the machine tool. An additional power unit for power workholding is no longer necessary.

With the sturdy swing mechanism and the optional position monitoring these swing clamps are particularly suitable for:

- Automatic manufacturing systems with very short cycle times
- Clamping fixtures with workpiece loading by handling systems
- Transfer lines
- Test systems for motors, gears and axes
- Assembly lines
- Special machine tools

Description

The hydraulic swing clamp is a pull-type cylinder where a part of the total stroke is used to swing the piston.

Due to the sturdy swing mechanism the angle position of the clamping arm remains the same after a slight collision with the workpiece during loading and unloading or during clamping.

The angle position of the clamping arm is fixed with a dowel pin.

The FKM wiper at the piston rod can be protected against coarse and hot swarf by an optionally available metallic wiper (see page 6). The version with extended switch rod is provided for mounting of pneumatic or electrical position monitorings (accessory).

Important notes see page 6.

Installation and connecting possibilities

Pipe thread

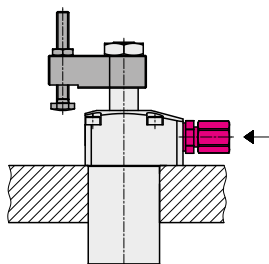

Drilled channels

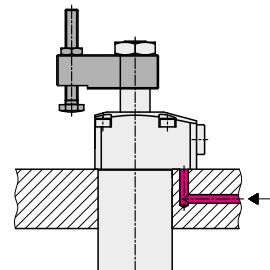

Versions

Without switch rod

185XT

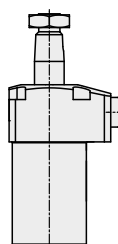

With switch rod

185XQ

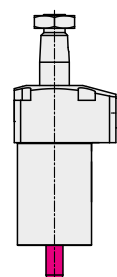

Accessories

Pneumatic position monitoring

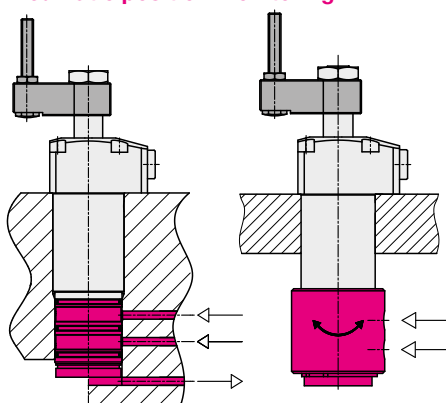

Electrical position monitoring

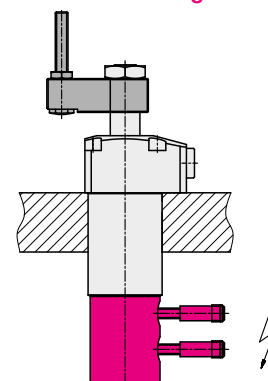

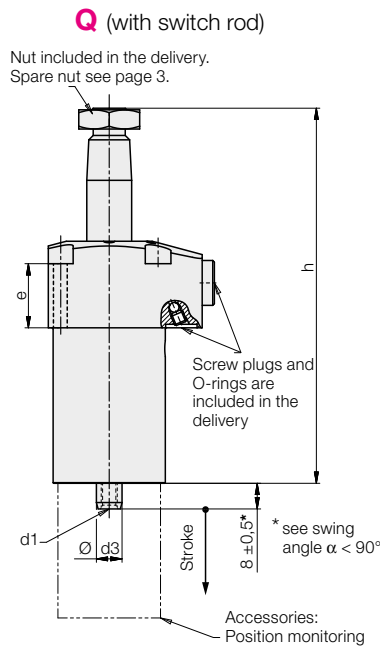
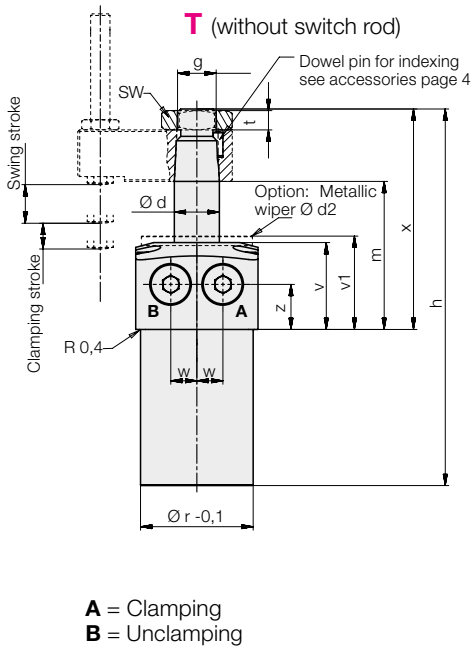

Accessories
Pneumatic position monitoring (page 5)
 Cartridge type

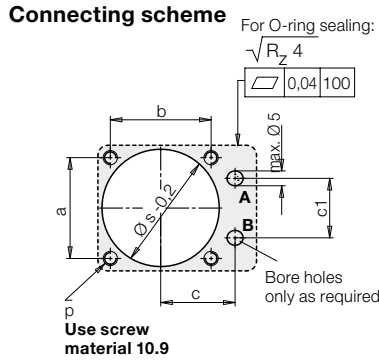
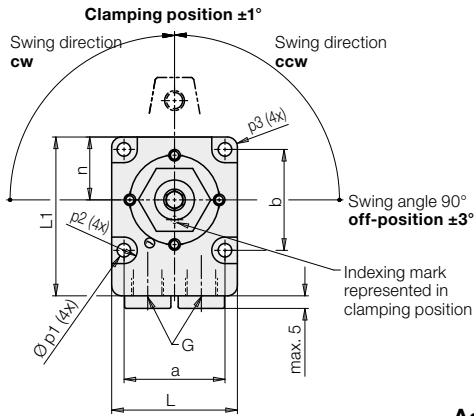
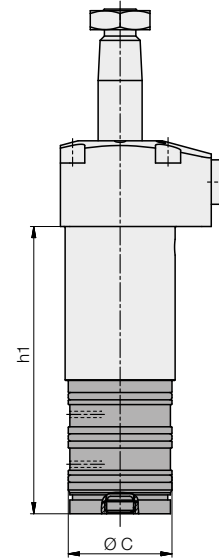

Connection: pipe thread

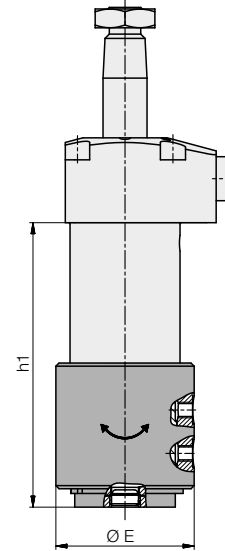

Swing angle

1. Swing angle 90° and 0° (standard)

Part no.
90° cw 185XX090RXX
90° ccw 185XX090LXX
0° 185XX0000XX

2. Swing angle $\alpha < 90^\circ$

$\alpha = 15^\circ$ to 75° in gradation of 5°

By insertion of a distance plate the return stroke of the piston is reduced and thus the swing angle is reduced.

Clamping stroke and clamping position remain the same. The swing stroke and the dimensions h, m and x are reduced by y:

$$y = (90^\circ - \alpha^\circ) * k \quad (k \text{ see chart page 3})$$

Dimension 8 ± 0.5 is lengthened by the value y.

Example:

Swing clamp	1856T090L27
Desired swing angle	45° ccw
Part no.	1856T045L27

Shortening:

$$y = (90^\circ - 45^\circ) * 0.125 \text{ mm}/^\circ = 5.625 \text{ mm}$$

3. Swing angle $> 90^\circ$

Available on request!

Important notes see page 6.

Operating conditions, tolerances and other data see data sheet A 0.100.

Accessory Throttle valve

Throttle valves are used

- in order to reduce the swing speed of the clamping arm;
- in order to improve the synchronism of several swing clamps.

This application is only possible for manifold-mounting connection through drilled channels.

Hydraulic symbol

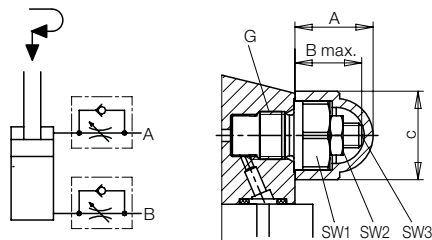

Swing clamps	1853	1856
A	[mm] 16	21
B max.	[mm] 13.5	17.5
C	[mm] 18	23.6
G	G 1/8	G 1/4
SW1	[mm] 14	19
Tightening torque	[Nm] 18	35
SW2	[mm] 8	8
SW3	[mm] 2.5	2.5
Weight	[kg] 0.025	0.036
Part no.	2957 209	2957 210

Electrical position monitoring (page 6)

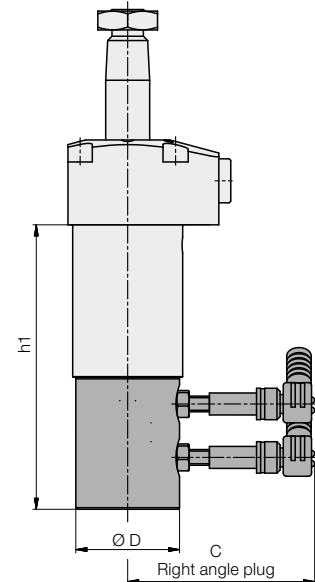

Technical data

Max. pulling force (70 bar)	[kN]	2.35	4.46	9.9	16.1	
Effective clamping force	[kN]	see diagram or calculation of the clamping force on page 4				
Clamping stroke	[mm]	8	8	10	10	
Swing stroke	[mm]	8	13	17	19	
Total stroke	[mm]	16	21	27	29	
Min. operating pressure	[bar]	20	20	20	20	
Max. flow rate	Clamping	[cm ³ /s]	13.5	33.5	96	167
	Unclamping	[cm ³ /s]	20	53.5	145	255
Piston area	Clamping	[cm ²]	3.36	6.37	14.16	23
	Unclamping	[cm ²]	4.9	10.17	21.23	33.18
Oil volume / stroke	[cm ³]	5.4	13.4	38.3	66.7	
Oil to return	[cm ³]	7.9	21.4	57.4	102	
Piston Ø	[mm]	25	36	52	65	
a	[mm]	30.5	40	56	68	
b	[mm]	30.5	40	56	68	
c	[mm]	22.5	28	36	42	
c1	[mm]	18	24	36	45	
Ø d	[mm]	14	22	30	36	
Ø d1	[mm]	M5 x14.5 deep	M6 x11.5 deep	M8 x16.0 deep	M8 x16.0 deep	
Ø d2	[mm]	34.5	44.5	52.5	58.5	
Ø d3 f7	[mm]	8	10	12	12	
e	[mm]	20	19.5	19	23.5	
SW	[mm]	SW 19	SW 27	SW 36	SW 46	
g	[mm]	M12	M18x1.5	M24x1.5	M30x1.5	
G		G 1/8	G 1/8	G 1/4	G 1/4	
h	[mm]	117	149	178.5	203.5	
h1	[mm]	90.5	110	132	141	
k	[mm/°]	0.056	0.095	0.125	0.125	
L	[mm]	38	50	70	86	
L1	[mm]	48	60	82	96	
m	[mm]	46	54	64.5	72.5	
n	[mm]	19	25	35	43	
p	[mm]	M4 (10.9)	M5 (10.9)	M8 (10.9)	M10 (10.9)	
Ø p1	[mm]	4.3	5.5	9	11	
p2	[mm]	4	5	7	9	
p3	[mm]	3	3	6	7	
Ø r -0.1	[mm]	35	47	63	78	
Ø s -0.2	[mm]	36	48	64	79	
t	[mm]	6	9	10	12	
v	[mm]	27	29.5	34.5	39	
v1	[mm]	29	31.5	36.5	41	
w	[mm]	8.1	11	15	19	
x	[mm]	68.5	88	101.5	119.5	
z	[mm]	14	13.5	15.5	15.5	
Weight, approx.	[kg]	0.7	1.5	3.0	5.0	
Part no.	Swing direction 90° cw	1853 X090R16M	1854 X090R21M	1856 X090R27M	1857 X090R29M	
	Swing direction 90° ccw	1853 X090L16M	1854 X090L21M	1856 X090L27M	1857 X090L29M	
	0 degree	1853 X000016M	1854 X000021M	1856 X000027M	1857 X000029M	
Spare O-ring	[mm]	7 x 1.5	7 x 1.5	8 x 1.5	8 x 1.5	
Part no.		3000342	3000342	3000343	3000343	
Spare nut DIN 936		M12	M18x1.5	M24x1.5	M30x1.5	
Tightening torque	[Nm]	12	30	62	110	
Part no.		3302115	3301663	3302104	3302139	

Code letter **X** see page 2.

M = Option metallic wiper (see also page 6)

Effective clamping force with accessory clamping arm as a function of the oil pressure

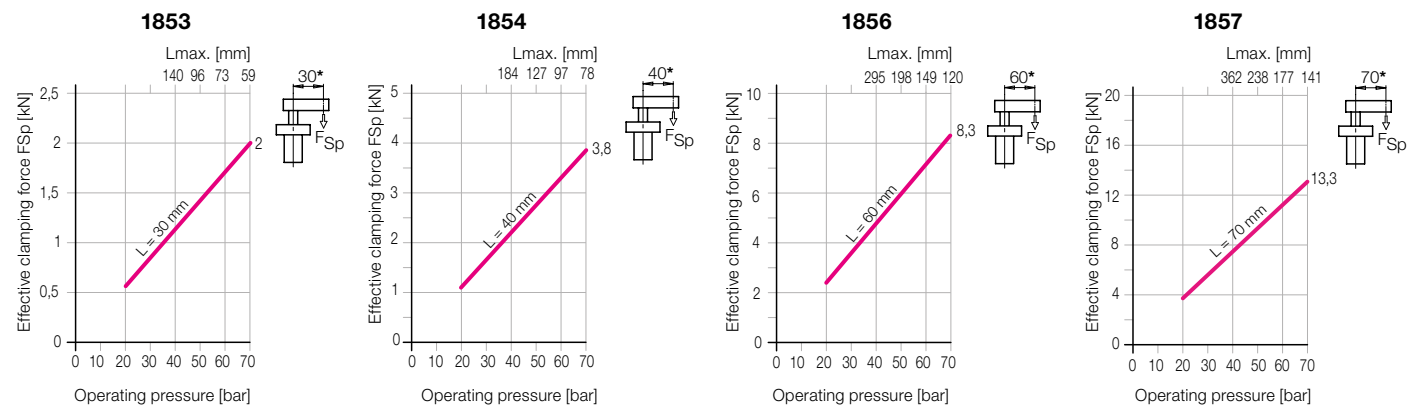

* Clamping force for other lengths see page 4.

Accessories - Clamping arms • Metallic wipers

Calculation of the flow rate • Calculation of the clamping force

Dimensions for special clamping arms

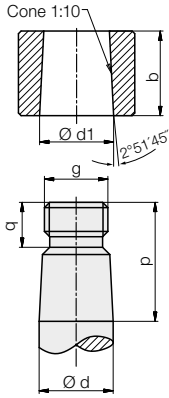

Clamping arm, max. 70 bar

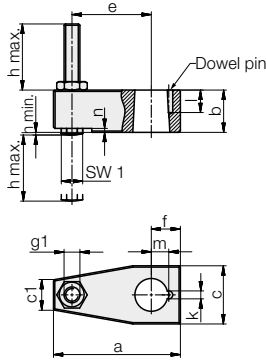

Special clamping arm

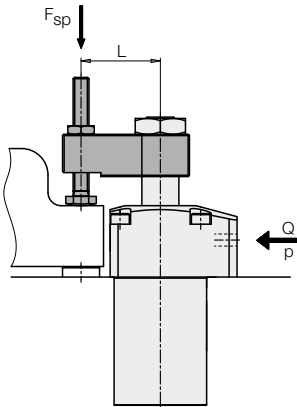
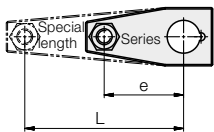

Adm. flow rate and clamping time as a function of the clamping arm extension

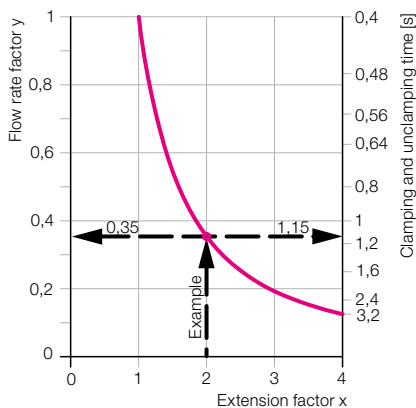

Swing clamps	1853	1854	1856	1857
a	48	65	96	114
b	16	25	27	35
c	22	34	52	60
c1	12	19	31	36
Ø d	14	22	30	36
Ø d1 -0.05	14	22	30	36
e	30	40	60	70
f	11	17	25	30
g	M12	M18x1.5	M24x1.5	M30x1.5
g1	M6	M8	M12	M16
h min.	1	1	1	1
h max.	40	46	54	63
Ø k +0.1	3	3	6	6
l +0.5	8.5	8.5	12.5	12.5
m ±0.05	6.6	10.3	15	18.1
n	1.5	2.5	6	8
p	22.5	34	37	47
q	8.5	11.5	12.5	15.5
SW 1	8	10	18	24
Moment of inertia of J _e	44	230	1284	3247

Part no.

Clamping arm with contact bolt and dowel pin	0354243	0354249	0354254	0354256
Dowel pin	3 m 6x8	3 m 6x8	6 m 6x12	6 m 6x12
	3301854	3301854	3300325	3300325
Metallic wiper	0341227	0341228	0341229	0341230

Admissible flow rate

With the accessory clamping arm and the admissible flow rate as per chart (page 3) the shortest clamping time is approx. 0.4 seconds. Longer special clamping arms have a higher torque of inertia. To avoid an overload of the swing mechanism, the flow rate has to be reduced:

$$Q_L = Q_e \cdot \sqrt{\frac{J_e}{J_L}} \text{ cm}^3/\text{s}$$

Q_e = Flow rate as per chart (page 3)
 Q_L = Flow rate with special clamping arm
 J_L = Torque of inertia accessory clamping arm
 J_e = Torque of inertia special clamping arm

If the torques of inertia are not known, the admissible flow rate can be determined according to the following example:

Conditions: The special clamping arm is longer, has however the form (cross section) of the accessory clamping arm, as shown on the left.

Example: Swing clamp 1853T090R16
 L = 60 mm
 e = 30 mm as per above chart
 Q_e = 13.5 cm³/s (as per chart page 3)

- Extension factor $x = \frac{L}{e} = \frac{60 \text{ mm}}{30 \text{ mm}} = 2$
- Flow rate factor as per diagram $\rightarrow y = 0.35$
- Max. flow rate $Q_L = y \cdot Q_e = 0.35 \cdot 13.5 \text{ cm}^3/\text{s} = 4.7 \text{ cm}^3/\text{s}$
- Min. clamping time as per diagram \rightarrow approx. 1.15 s

Throttling of the flow rate

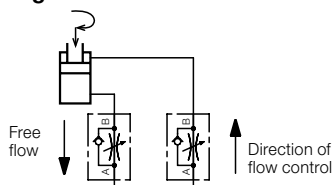

Calculation of the clamping force

The diagrams on page 3 show the effective clamping force with accessory clamping arm (L = e).

With longer clamping arms (L > e) the degree of efficiency is reduced. This is considered in the following calculation.

The constants (A...E) for the 4 sizes are shown in the chart.

Constant	1853	1854	1856	1857
A	29.68	15.68	7.06	4.35
B	0.177	0.069	0.023	0.013
C	102.9	260.5	853.8	1596
D	3053	4087	6026	6939
E	18.2	17.86	19.55	20.86

Effective clamping force

$$F_{Sp} = \frac{p}{A + (B \cdot L)} \leq F_{adm.} \text{ [kN]}$$

Admissible clamping force*)

$$F_{adm} = \frac{C}{L} \text{ [kN]}$$

Admissible operating pressure

$$p_{adm} = \frac{D}{L} + E \leq 70 \text{ [bar]}$$

L = special length [mm] p = pressure [bar]

*) With a desired clamping arm length L the clamping force must not exceed the admissible value.

Example: Swing clamp 1853T090R16
 Special clamping arm L = 60 mm

1. Admissible clamping force*)

$$F_{adm} = \frac{C}{L} = \frac{102.9}{60} = 1.71 \text{ kN}$$

2. Admissible operating pressure

$$p_{adm} = \frac{D}{L} + E = \frac{3053}{60} + 18.2 = 69 \text{ bar} < 70$$

3. Effective clamping force

$$F_{Sp} = \frac{p}{A + (B \cdot L)} = \frac{69}{29.68 + (0.177 \cdot 60)} = 1.71 \text{ kN}$$

Accessories

Pneumatic position monitoring • Mounting body

Application

The pneumatic position monitoring signals the following conditions by closing two bore holes:

1. Piston extended and clamping arm in off-position.
2. Piston in clamping area and clamping arm in clamping position.

For each control function, a pneumatic line has to be provided at the clamping fixture.

Description

The cartridge type of the pneumatic position monitoring can be easily retrofitted at all swing clamps with switch rod (185XQ0XX). When moving to a switching position, the air pressure in the supply line increases and operates a differential pressure switch or an electro-pneumatic pressure switch.

Pneumatic port

Cartridge type

The swing clamp with the mounted position monitoring and inserted O-rings is put into the location hole and immediately ready for use.

Mounting body

The mounting body is put onto the cartridge-type version and held by the supplied safety ring. The pneumatic ports M5 can be rotated by 360°.

Monitoring by pneumatic pressure switch

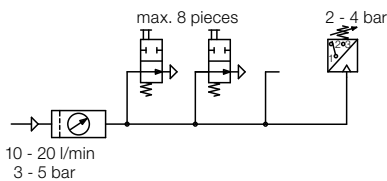

For the evaluation of the pneumatic pressure increase standard pneumatic pressure switches can be used. With one pressure switch up to 8 position monitorings can be controlled (see circuit diagram). It has to be considered that process-safe functioning of pneumatic controls is only guaranteed with throttled air pressure and air flow rate.

Technical data

Connection	Drilled channels or threads M5
Nominal diameter	2 mm
Max. air pressure	10 bar
Range of operating pressure	3...5 bar
Differential pressure*) at	
3 bar system pressure	min. 1.5 bar
5 bar system pressure	min. 3.5 bar
Air volume **)	10...20 l/min

*) Minimum pressure difference, if one or several position monitorings are not operated.
 **) For measuring of the flow rate appropriate devices are available.

Function chart

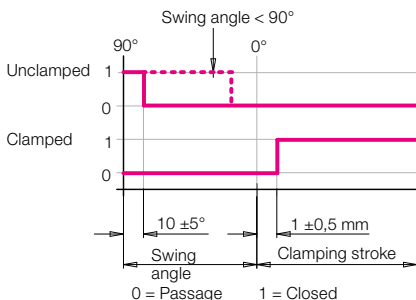

Cartridge type

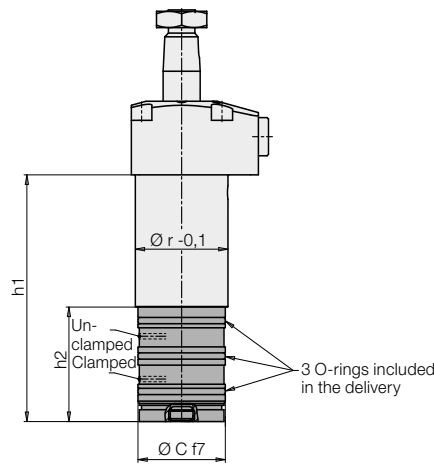

Connection: pipe thread

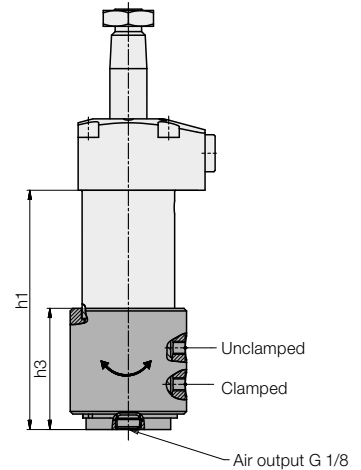

Location hole

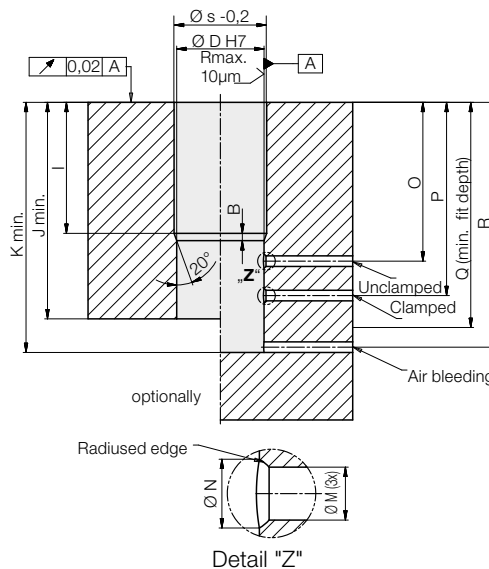

Mounting body

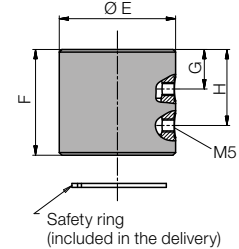

Swing clamps	1853Q0XX	1854Q0XX	1856Q0XX	1857Q0XX
Ø A	[mm] 35	47	63	78
B	[mm] 2.5-0.5	2.5-05	2.5-0.5	2.5-0.5
Ø C f7	[mm] 33	42	45	45
Ø D H7	[mm] 33	42	45	45
Ø E	[mm] 44	53	56	56
F	[mm] 40	47	48.8	50.8
G	[mm] 14.95	16.35	13.4	14.05
H	[mm] 28.75	33.35	35.4	36.75
h1	[mm] 90.5	110	132	141
h2	[mm] 42	49	55	57
h3	[mm] 46	53	54.8	56.8
I	[mm] 49.5	62	78	85
J min.	[mm] 83	101.5	123.5	132.5
K min.	[mm] 94.5	114	136	145
Ø M	[mm] 4	4	4	4
Ø N	[mm] 5	5	5	5
O	[mm] 60	73.5	89.5	96.5
P	[mm] 73	90.5	111.5	118.5
Q min.	[mm] 85	103	125	134
R	[mm] 92.5	112	134	143
Ø r -0.1	[mm] 35	47	63	78
Ø s -0.2	[mm] 36	48	64	79

Part no. Cartridge type

Swing angle				
0° or 90°	0353918	0353924	0353928	0353941
15° to 75° = XX*)	03539180XX	03539240XX	03539280XX	03539410XX

Part no. Mounting body for retrofitting of the cartridge type

	0353950	0353951	0353952	0353953
--	---------	---------	---------	---------

*) in gradation of 5° (see page 2, "swing angle $\alpha < 90^\circ$ ")

Application

The electrical position monitoring signals the following conditions due to damping of two inductive proximity switches:

1. Piston extended, clamping arm in off-position.
2. Piston in clamping area, clamping arm in clamping position.

For each control function, an electrical line has to be provided at the clamping fixture.

Description

The electrical position monitoring can be easily retrofitted at all swing clamps with switch rod (185XQ0XX).

Included in our delivery are:

- 1 Signal sleeve with screws
- 1 Adapter with 4 countersunk screws
- 1 Control housing with 3 set screws
- 2 Inductive proximity switches with right angle plug (if ordered)

The signal sleeve is screwed onto the switch rod.

The adapter is mounted with 4 countersunk screws at the bottom cover.

The control housing can be put onto the adapter in any angular position and locked with 3 set screws.

For information on adjustment of proximity switches, see operating manual.

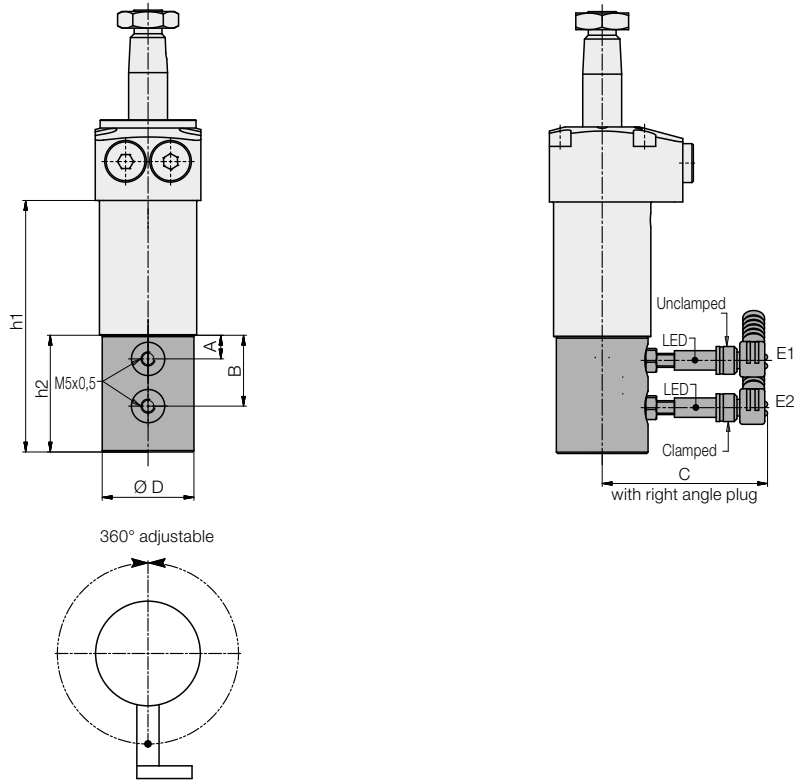

Possible position of the proximity switches

Important notes

Inductive position monitorings are not suitable for the use in coolant and swarf areas. According to the corresponding application conditions, safety measures have to be planned and checked later on.

Technical data

Operating voltage	10...30 V DC
Max. residual ripple	10%
Max. constant current	100 mA
Switching function	interlock
Output	PNP
Housing material	stainless steel
Thread	M 5 x 0.5
Code class	IP 67
Ambient temperature	-25...+70 °C
LED Function display	yes
Protected against short circuits	yes
Connection type	Plug
Length of cable	5 m

Function chart

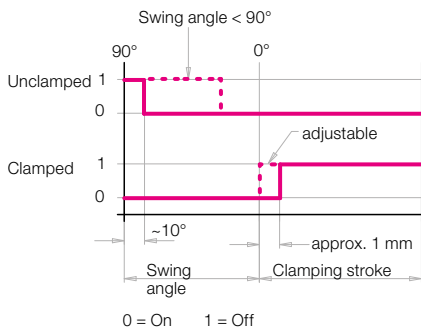

Swing clamps	1853Q0XX	1854Q0XX	1856Q0XX	1857Q0XX
A	[mm] 8.5	8.5	8.5	8.5
B	[mm] 25.5	30.5	37.5	39.5
C approx.	[mm] 59.5	61	62	62
Ø D	[mm] 33	42	45	45
h1	[mm] 90.5	110	132	141
h2	[mm] 42	49	55	57

Part no. Swing angle 0° or 90°

with switch and plug	0353920	0353926	0353930	0353943
without switch and plug	0353923	0353927	0353931	0353944

Part no. 15° to 75° = XX*

with switch and plug	0353920XX	0353926XX	0353930XX	0353943XX
without switch and plug	0353923XX	0353927XX	0353931XX	0353944XX

Part no. Spare parts

Inductive proximity switch	3829198	3829198	3829198	3829198
Right angle plug 5 m	3829099	3829099	3829099	3829099

*) in gradation of 5° (see page 2, "swing angle $\alpha < 90^\circ$ ")

Important notes

Swing clamps must only be used for clamping of workpieces in industrial applications and may only be operated with hydraulic oil. They can generate very high forces. The workpiece, the fixture or the machine must be in the position to compensate these forces.

In the effective area of piston rod and clamping arm there is the danger of crushing.

The manufacturer of the fixture or the machine is obliged to provide effective protection devices. The swing clamp has no overload protection device. When mounting the clamping arm, the clamping arm or the hexagon socket in the piston have to be backed up for tightening or untightening the fixing nut.

During loading and unloading of the fixture and during clamping a collision with the clamping arm has to be avoided.

Remedy: Mount position adaptor.

Wiper system

The standard FKM wiper has a high chemical resistance against most cooling and cutting fluids.

The optional metallic wiper protects the FKM wiper against mechanical damage due to big or hot swarf.

It consists of a radially floating wiping disk and a retaining disk.

The metallic wiper can be delivered already mounted ("M") or as an accessory for retrofitting (see page 4).

Attention!

The metallic wiper is not suitable for dry machining or minimum quantity lubrication. Also in applications with very little grinding swarf, the standard FKM wiper has a better protection effect.

If there is any danger that small particles stick to the piston rod, the metallic wiper disk can also be replaced by a hard plastic disk.