



## Threaded-Body Work Supports with metallic wiper edge, single acting, max. operating pressure 70 bar



### Advantages

- High support force at 70 bar
- 4 sizes available
- Space-saving threaded-body version
- Metallic wiper edge and FKM wiper
- Connection for venting and positive air pressure protection
- Corrosion-resistant interior parts
- Standard flow rate throttle
- Mounting body as accessory
- Mounting position: variable

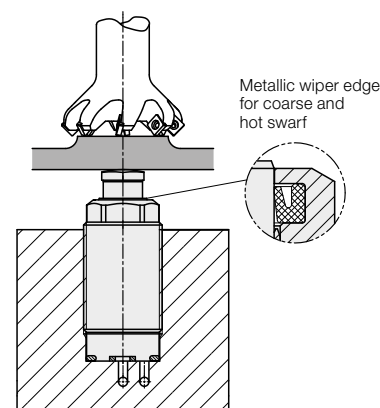

### Application

Hydraulic work supports are used to provide a self-adjusting rest for the workpiece during the machining operations. They compensate the workpiece surface irregularities, also vibration and deflection under machining loads.

This series offers very high support forces already at 70 bar and can directly be connected to the low-pressure hydraulic of the machine tool.

### Description

The support plunger is hydraulically extended by a small piston and contacts the workpiece with spring force. The pressure can be easily exchanged.

Locking of the support plunger through the slotted clamping sleeve is made by means of a ring-shaped conical hydraulic piston where the locking force is transmitted by a low-friction ball shell.

Unlocking and retracting of the support plunger is made by spring force.

### Important notes!

Work supports are not suitable to compensate side loads. The support plunger must not be stressed by tensile load.

The admissible load force is valid for static or dynamic load. Machining forces can generate vibrations, whose amplitude exceeds far an average value, and this can cause yielding of the support plunger.

Safe functioning is only guaranteed with open venting hole. At the end of the bore hole suction of liquids must be avoided. It is recommended to connect positive air pressure protection with 0.2 bar.

For unclamping the air sealing must be switched off.

The maximum pressure in the return line must not exceed 1.5 bar.

Work supports must only be operated with a sealed contact bolt.

Operating conditions, tolerances and other data see data sheet A 0.100.

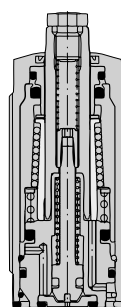

### Installation and connecting possibilities

#### Drilled channels

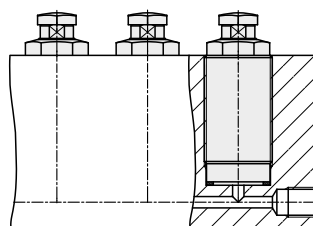

#### Pipe thread

#### with accessory mounting body

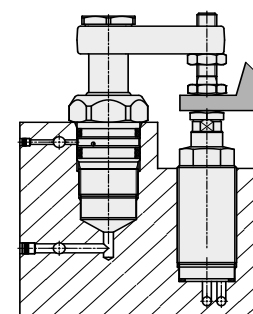
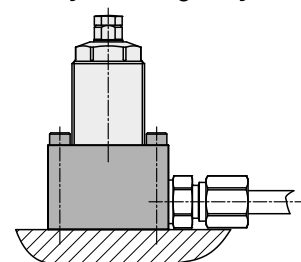

### Combination with clamping elements

If clamping will be made onto the work supports, the clamping force must be adjusted to the admissible load, so that there will be still a sufficient reserve to compensate the machining forces.

Rough estimate:

**Min. load force  $\geq 2 \times$  clamping force**

### Example

Threaded-body work support 1947-200  
Swing clamp 1853-A090-R16  
Operating pressure 70 bar

As per diagram:

Adm. load	4.0 kN	4.0 kN
– Effective clamping force		2.0 kN
Reserve for machining force		2.0 kN

If this is not sufficient, the pressure for the swing clamp has to be reduced.

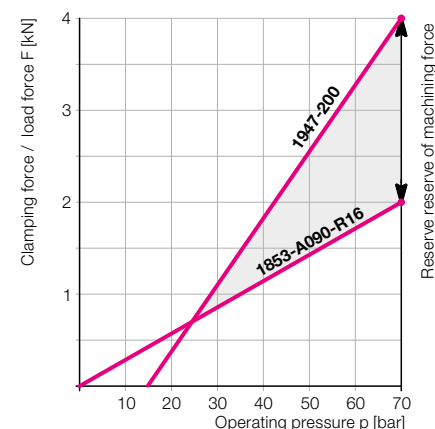

# Dimensions

## Technical data • Accessories

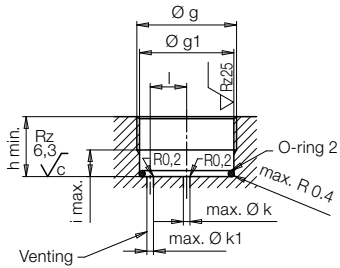
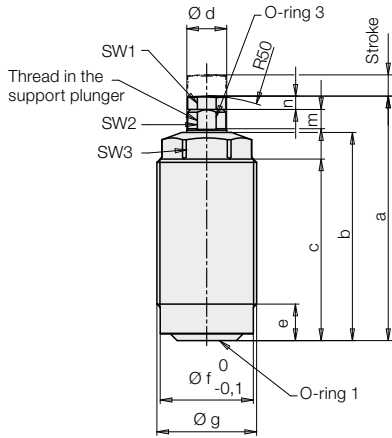

c = concentric grooves  
Not circularly milled!

### Mounting body (accessory)

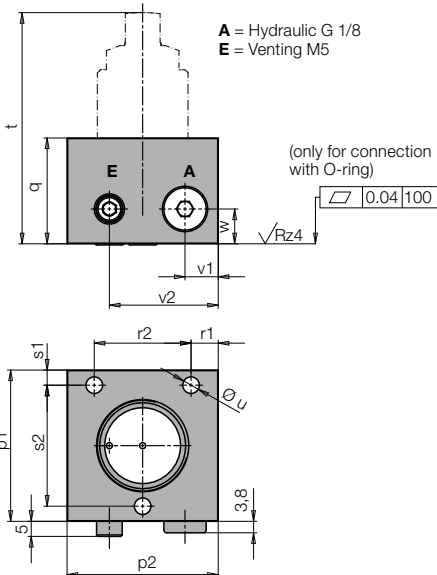
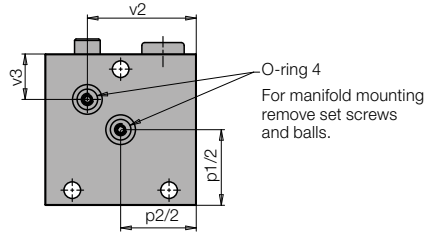

Adm. load force (70 bar)	[kN]	3	4	5.5	10
Load fore at p (bar)	[kN]	0.053xp-0.68	0.07xp-0.91	0.096xp-1.25	0.175xp-2.28
Support plunger Ø d	[mm]	10	12	15	16
Stroke	[mm]	6.5	8	8	10
Oil volume / stroke	[cm³]	0.6	0.9	1.3	2
Admissible flow rate	[cm³/s]	25	25	25	25
Recommended minimum pressure	[bar]	25	25	25	25
<b>Max. pressure of return flow</b>	<b>[bar]</b>	<b>1.5</b>	<b>1.5</b>	<b>1.5</b>	<b>1.5</b>
Spring force min./max.	[N]	3.7 / 9.5	7.0 / 12.0	9.7 / 14.8	8.5 / 14.8
Elastic deformation with load and 70 bar	[µm/kN]	9	6	6	3.5
Operating temperature	[°C]	0...70	0...70	0...70	0...70
Tightening torque	[Nm]	32	50	63	80
a	[mm]	66	73	69	82
b	[mm]	57	62	58	71
c	[mm]	49	54	49	62
e	[mm]	8.5	9.5	9.5	9.5
Ø f -1	[mm]	24	28	34	43
g	[mm]	M26x1.5	M30x1.5	M36x1.5	M45x1.5
Ø g1	[mm]	24.5	28.5	34.5	43.5
h min.	[mm]	16	17	18	20
i max.	[mm]	7	9	8	8.5
Ø k max.	[mm]	8	10	10	12
Ø k1 max.	[mm]	2.5	3	5	6
l	[mm]	9.5	11	13	15
m	[mm]	5	6	6	6
n	[mm]	3	4	4	4
p1	[mm]	45	50	60	70
p2	[mm]	45	50	50	55
q	[mm]	35	35	35	35
r1	[mm]	6.5	9	6	8.5
r2	[mm]	32	32	38	38
s1	[mm]	4.5	5	6	6
s2	[mm]	36	40	48	58
t	[mm]	83	90	84	97
Ø u	[mm]	5.5	5.5	6.5	6.5
v1	[mm]	8.5	11	11	13.5
v2	[mm]	32	36	38	42.5
v3	[mm]	12.5	15	20	25
w	[mm]	11.5	11.5	11.5	11.5
SW 1	[mm]	8	10	11	11
SW 2	[mm]	8	10	13	13
SW 3	[mm]	22	24	30	36
Thread in support plunger		M6x8	M8x13	M10x13	M10x13
Weight approx.	[kg]	0.2	0.25	0.35	0.75

Part no.	1947-100	1947-200	1947-300	1947-400
<b>Accessories</b>				
Mounting body complete	<b>0346-809</b>	<b>0346-810</b>	<b>0346-811</b>	<b>0346-812</b>

Spare parts	3001-013	3001-862	3001-967	3001-968
O-ring 1	<b>3001-013</b>	<b>3001-862</b>	<b>3001-967</b>	<b>3001-968</b>
O-ring 2	<b>3002-170</b>	<b>3001-640</b>	<b>3002-171</b>	<b>3002-172</b>
O-ring 3	<b>3002-167</b>	<b>3001-526</b>	<b>3000-275</b>	<b>3000-275</b>
O-ring 4	<b>3000-342</b>	<b>3000-342</b>	<b>3000-342</b>	<b>3000-342</b>

### Mounting body complete (accessory)

In combination with mounting bodies the threaded-body work supports become individual components ready for installation. For pipe connection there are connecting threads G 1/8 and M 5 for hydraulics and venting.

A manifold-mounting connection with thrilled channels is also possible. For this purpose the screw plugs in the manifold-mounting surface will be removed and the supplied O-rings inserted in the counterbores. The pipe connections remain closed.

O-rings and screw plugs are included in the delivery.

### Load force as a function of the operating pressure

