



Threaded-Body Work Supports
with metallic wiper edge,
double acting, max. operating pressure 70 bar



Advantages

- High process safety by double-acting function
- Space-saving threaded-body version
- 4 sizes available
- Load force up to 10 kN at 70 bar
- Workpiece contact by spring force
- Metallic wiper edge
- Protected FKM wiper
- Inner parts protected against corrosion
- Venting of the spring area
- Connection of positive air pressure protection possible
- Installed orifice for flow rate limitation
- Mounting position: any

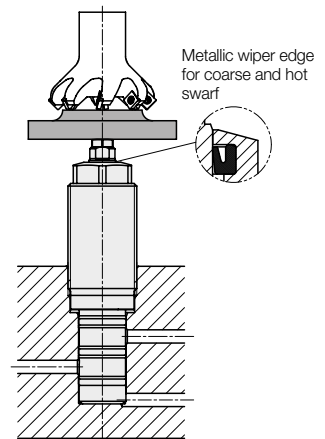

Application

Hydraulic work supports are used to provide a self-adjusting rest for workpieces and avoid their vibration and deflection under machining loads. This series offers high support forces already at 70 bar and can directly be connected to the low-pressure hydraulics of the machine tool. In case of the double-acting version, the return stroke of the support plunger is effected in a precisely defined time, that is above all advantageous in cycle-dependent installations.

Description

The support plunger is hydraulically extended and retracted by means of a small double-acting cylinder. Contact to the workpiece is made by spring force. The pressure can be easily exchanged. Locking of the support plunger through the slotted clamping sleeve is made by means of a ring-shaped conical hydraulic piston where the locking force is transmitted by a low-friction ball shell. Unlocking of the support plunger is made by spring force.

Function

The support plunger is retracted in off-position. When pressurised, the piston of the double-acting cylinder extends against an internal stop and the support plunger contacts the already clamped workpiece with spring force. With continuing pressure increase, the conical hydraulic piston moves downwards. The support plunger will be radially locked by the slotted locking bush using a low-friction spherical shell and can then compensate load forces in axis direction. For unclamping, hydraulic pressure will be released. The conical hydraulic piston is pushed upwards by spring force, whereby the locking of the support plunger disengages. At the same time, the return line is pressurised and the piston of the double-acting cylinder retracts the support plunger back to the off-position.

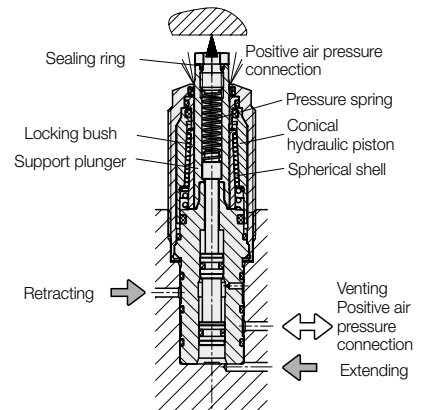

Important notes!

Work supports are not suitable to compensate side loads. The support plunger must not be stressed by tensile load.

The admissible load force is valid for static or dynamic load. Machining forces can generate vibrations, whose amplitude exceeds far an average value, and this can cause yielding of the support plunger.

Remedy: Increase the safety factor or the number of work supports.

Work supports must only be operated with a sealed contact bolt.

In dry machining applications, with minimum quantity lubrication or in case of accumulation of very small swarf, there can be a swarf holdup in the area of the metallic wiper edge.

Remedy: Regular cleaning.

Operating conditions, tolerances and other data see data sheet A 0.100.

Venting port

To guarantee safe functioning, a vent port is imperative. It is important that no liquids can penetrate into the venting system.

Positive air pressure connection

By connecting a slight overpressure of max. 0.2 bar, the venting system is effectively protected against the penetration of liquids. If the support plunger is retracted, the positive air pressure connection can be switched off.

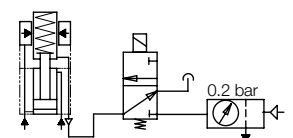

Combination with clamping elements

With this combination, clamping and machining forces will add up:

$$\begin{aligned} &\text{Clamping force} \\ &+ \text{max. machining force} \\ &= \text{minimum support force} \times \text{safety factor} \end{aligned}$$

Rough calculation from practice:

Required support force $\geq 2 \times$ clamping force

To increase the safety, a support force as high as possible should be achieved by

- using a larger work support
- utilising the max. operating pressure
- using a smaller clamping element or reducing the clamping pressure

Important note

The positive air pressure must be free of oil and water.

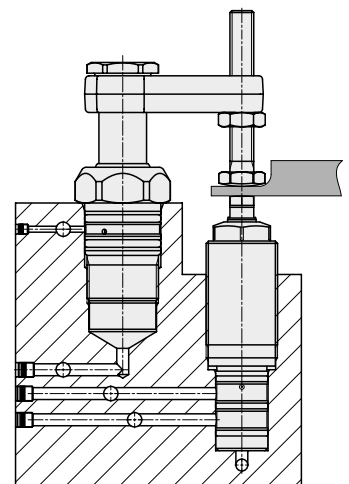

Technical data Accessories • Dimensions

Part no. 1947 X10

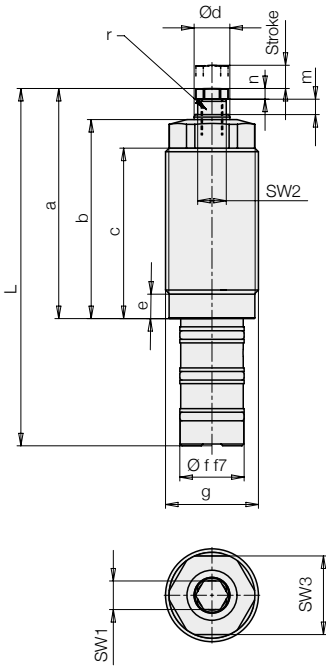

Location hole with radiused connecting bores

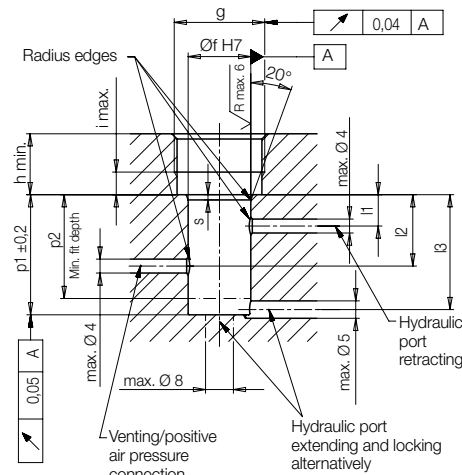

Dimensions for self-made contact bolts

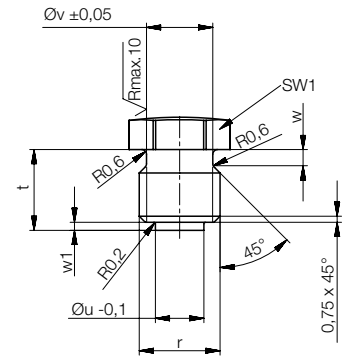

Location hole with entering slopes

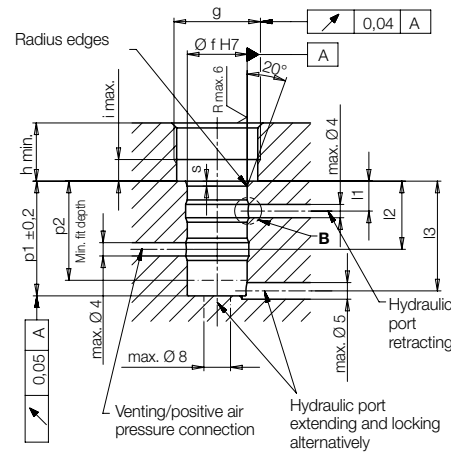

Detail "B"

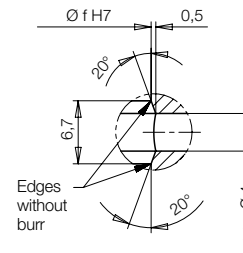

Pay attention when mounting:
The location hole must be dry and oil-free to ensure that no liquids penetrate into the spring area of the work supports.

When exchanging work supports:
To get a dry location hole, the hydraulic oil in drilled channels must be removed.

Adm. load force F As a function of the operating pressure p

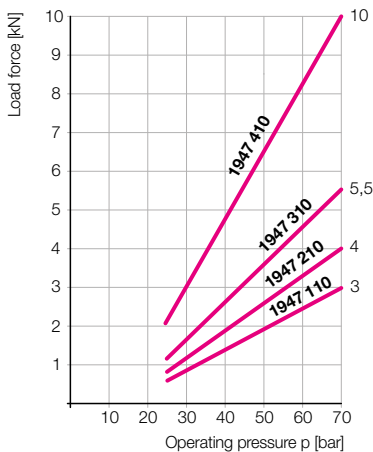

Elastic deformation with load force F and operating pressure 70 bar

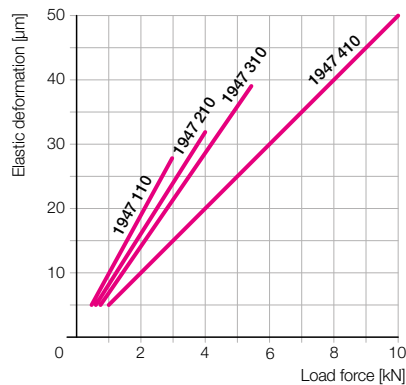

Spring contact force F_F as a function of the support plunger stroke h

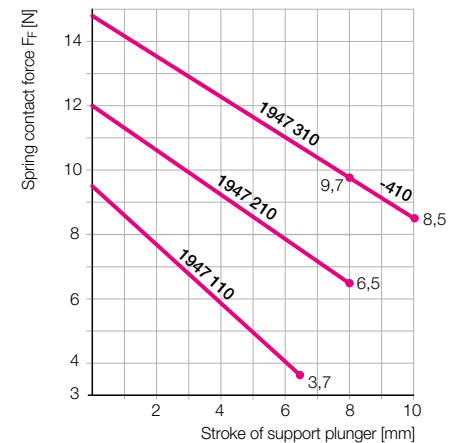

Technical data

Adm. load force (70bar)	[kN]	3	4	5.5	10
Load force at p (bar)	[kN]	0.053xp-0.68	0.07xp-0.91	0.096xp-1.25	0.175xp-2.28
Support plunger Ø d	[mm]	10	12	15	16
Stroke	[mm]	6.5	8	8	10
Oil volume extending	[cm³]	0.7	1	1.1	1.9
retracting	[cm³]	0.07	0.1	0.12	0.35
Recommended minimum pressure	[bar]	25	25	25	25
Spring force min./max.	[N]	3.7/9.5	7.0/12.0	9.7/14.8	8.5/14.8
Elastic deformation with load and 70 bar	[µm/kN]	9	8	7	5
Operating temperature	[°C]	0...70	0...70	0...70	0...70
Tightening torque	[Nm]	32	50	63	80
L	[mm]	100	107	109	120
a	[mm]	64.4	71.55	68.4	80.6
b	[mm]	55.7	60.6	56.5	69.5
c	[mm]	47.7	52.6	47.5	60.5
e	[mm]	7	8	8	8
Ø f H7/f7	[mm]	18	22	24	28
g	[mm]	M26x1.5	M30x1.5	M36x1.5	M45x1.5
h min.	[mm]	17.5	20.5	19	20
i max.	[mm]	7	8	8	8.5
l1	[mm]	9	10	11	11.5
l2	[mm]	20.5	21.5	23.5	24
l3	[mm]	33	33	38	37
m	[mm]	4.3	5	6.8	6
n	[mm]	3	4	4	4
p1	[mm]	34.5	34.5	39	38.5
p2	[mm]	30	31	34	34
r thread in the support plunger x depth		M6x10	M8x11	M10x11	M10x11
s	[mm]	1.5	1.5	2	2
t	[mm]	8	10	10	10
Ø u	[mm]	3.1	5	6	6
Ø v	[mm]	4.5	6	8.2	8.2
w	[mm]	1.5	2	2	2
w1	[mm]	0.5	1	1	1
SW1	[mm]	8	10	11	11
SW2	[mm]	8	10	13	13
SW3	[mm]	22	24	30	36
Weight, approx.	[kg]	0.25	0.4	0.5	0.8
Part no.		1947 110	1947 210	1947 310	1947 410