

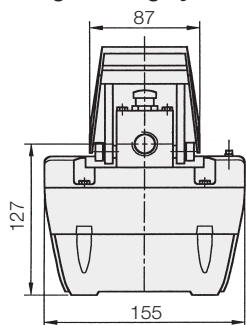

Hydro-Pneumatic Pump Unit
for single and double-acting cylinders
max. operating pressure 500 bar



For single-acting cylinders



Part-no. 8601-211

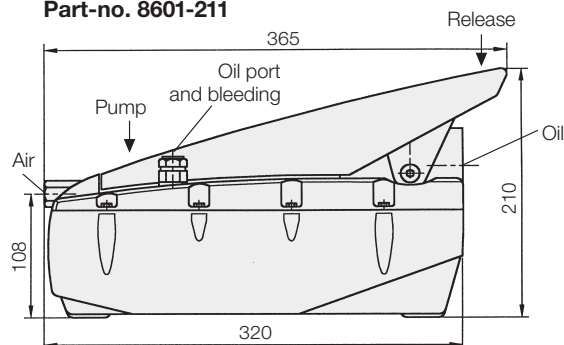

For double-acting cylinders

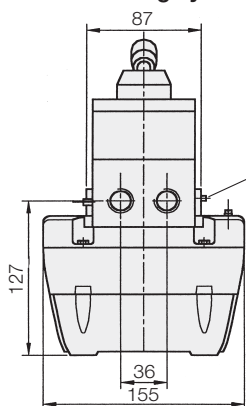

Part-no. 8601-221

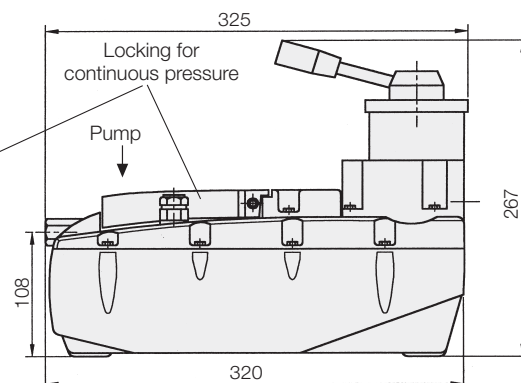

Application

The hydro-pneumatic pump unit is particularly suitable for smaller hydraulic clamping and assembly fixtures with single or double-acting hydraulic elements.

Description

Single-acting version

The single-acting hydro-pneumatic pump unit is manually operated. Only by operating the pedal will the fixture be clamped or unclamped. The pump delivers oil as long as the desired operating pressure is obtained. Air pressure is adjusted by a pneumatic service unit. Oil pressure is maintained by an integrated check valve. The pump does not automatically supply oil in case of leaks!

Double-acting version

By pushing the pedal, the connected double-acting hydraulic cylinders are extended or retracted according to the position of the manual 4/3 directional control valve. The pedal has to be pushed as long as the cylinders are in its final position and the desired oil pressure is obtained. After release of the pedal, the pump does not re-deliver in case of pressure drop on the oil side! The pedal can be locked by the laterally-arranged pin with the description "PUSH INTO LOCK", thereby the pump is continuously supplied with air. In this case the cylinders are exclusively activated by the manual 4/3 directional control valve. Small leaks are compensated by the pump and the oil pressure is maintained constantly.

Important note

For permanent industrial use we recommend the hydro-pneumatic pump as per data sheet D 8.600.

Delivery

The hydro-pneumatic pump unit is delivered with oil filling ready for connection. Preparation of the compressed air is made by an external service unit. Use of a lubricator is not required!

Advantages

- Suitable for mobile use
- Integrated safety valve avoids pressure increase over 500 bar independantly of the air pressure
- No health hazard oil mist when operating with non-lubricated air.

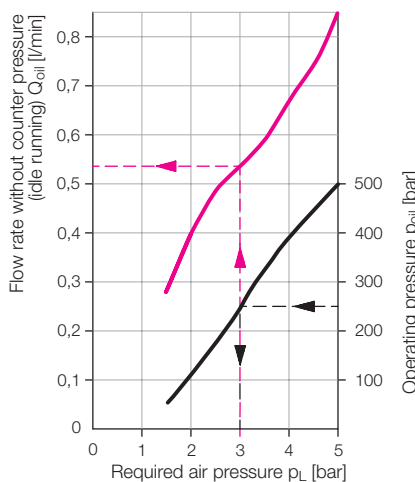

Example: For an operating pressure of $p_{oil} = 250$ bar an air pressure of $p_L = 3$ bar is adjusted at the preceding service unit. The flow rate Q_{oil} (without counterpressure) is approx. 0.54 l/min.

Technical characteristics

Max. flow rate	[cm ³ /s]	14.16
	[l/min]	0.85
Max. operating pressure*)	[bar]	500
Min. operating pressure	[bar]	50
Max. air pressure	[bar]	5
Min. starting pressure	[bar]	1.5
Max. air consumption	[Nl/min]	400
Transmission ratio		1:100
Max. oil volume	[l]	2.5
Usable oil volume	[l]	2.1
Connecting thread	[oil + air]	G1/4
Viscosity range	[10 – 6 m ² /s]	10 – 500
Recom. viscosity grade		ISO VG 22
Recom. hydraulic oil		HLP 22
		as per DIN 51524
Noise level		75 db [A] / 1m

Single-acting version

Weight	6.3 kg
Part-no.	8601-211

Double-acting version

Weight	6.8 kg
Part-no.	8601-221

Accessories

Service unit	Part-no. 9511-005
Pressure gauge (600 bar)	Part-no. 9846-000
Pressure gauge union	Part-no. 9208-040

*) On request, the max. operating pressure can be limited.

Circuit examples

Circuit example: single-acting version

Part-no. 8601-211

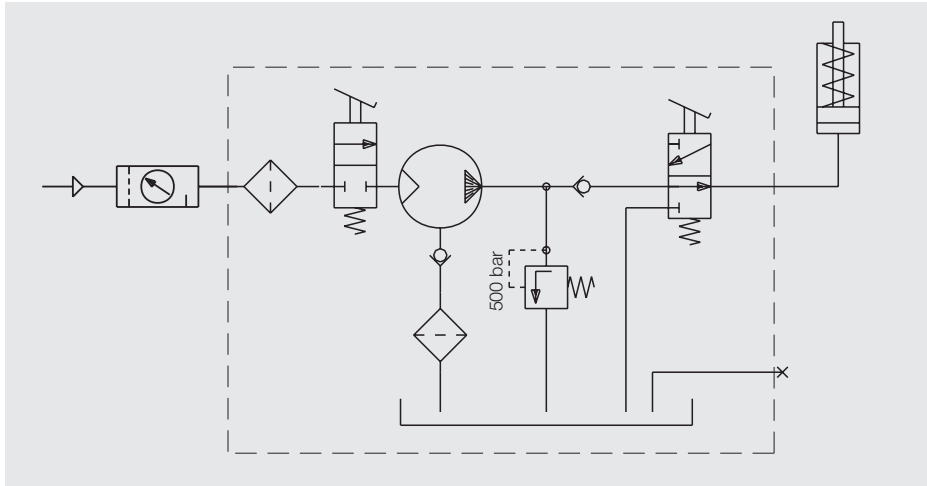

Circuit example: double-acting version

Part-no. 8601-221

