



Rotating Module - Horizontal Axis DMH 200

Max. load 2,000 N manual operation



Advantages

- Rotating in both directions
- Safe indexing
- Rotating and indexing possible by one-hand operation
- Compact device
- Sturdy design for industrial assembly
- Allows ergonomic working
- Safe and quick handling in assembly processes
- 4 function variants
- Easily combinable with other *modulog* modules

Application

Rotating module for universal use in assembly and handling processes in the industry.

Principal use

- Gear assembly
- Motor assembly
- Pump construction
- Turning operations during product transfer

Material

| | |
|---------------------|--------------------|
| Body: | steel, black oxide |
| Rotating plate: | steel, black oxide |
| Indexing mechanism: | steel, hardened |
| Bearing: | steel, hardened |

Mounting

To fix *modulog* modules or components of the user, the rotating module has a 140 x 140 *modulog* interface in the flange plate and the body.

In addition, at the bottom of the body 4 fixing threads are provided to allow vertical mounting of the rotating module.

As accessory for the vertical mounting onto other *modulog* modules an adaptor plate with an 140 x 140 *modulog* interface is available.

As accessory for individual fixing holes a round flange plate without 140 x 140 interface is available.

Description

The rotating module - horizontal axis DMH is a double supported rotation axis that can compensate high axial and radial forces. The angle of rotation in both directions is 360°. Due to special bearings it is insensitive to shocks and thrusts.

The design of the rotating module allows its integration in applications with light as well as with heavy loads.

When using the rotating module in assembly processes, component parts can be rotated rationally, quickly and safely and can be assembled ergonomically from all sides.

The rotating module is equipped with an optional indexing (see page 3 to 5).

Operation

The basic version of the rotating modules does not have any operating elements.

The rotating operation is manually effected at the workpiece or at the assembly fixture. Alternatively, versions with hand lever are available.

The indexing is operated by a hand lever of the rotating module or a separate hand lever or foot pedal.

modulog

Rotating module - horizontal axis DMH 200

Part-no. 650X-0X-XX-X-X

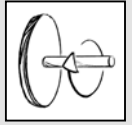

Technical characteristics

| | |
|--------------------|---------|
| Max. load: | 2,000 N |
| Max. torque: | |
| axial: | 800 Nm |
| radial: | 800 Nm |
| Angle of rotation: | 360° |

Operations

- Manual
- Hand lever

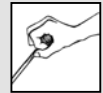

Indexing

Operation with

- Hand lever
- Foot pedal



Combinable with the modules

- Tilting module
KMB 100
as per data sheet M 2.101
- Rotating module – vertical axis
DMV 600
as per data sheet M 1.301
- Lifting module
as per data sheet M 4.XXX

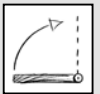

modulog interfaces

- Flange plate: 140 x 140 - M10
- Body: 140 x 140 - Ø 10.5 mm

Accessories

- Adaptor plates
as per data sheet M 8.110
- Flange plate
as per data sheet M 8.120

Version without indexing manual operation



Description

The rotating module - horizontal axis DMH 200 does not have an indexing in its basic version. The rotating operation is manually effected at the workpiece or at the assembly fixture.

Part-no. 6505-02-36-0

Technical characteristics

| | |
|------------------------|------------------------------|
| Operation: | manual at the component part |
| Angle of rotation: | 360° |
| Direction of rotation: | both directions |
| Indexing: | without |
| Weight: | 14 kg |

Maximum admissible load

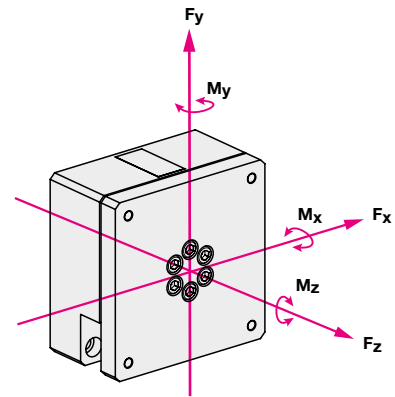

Dimensions

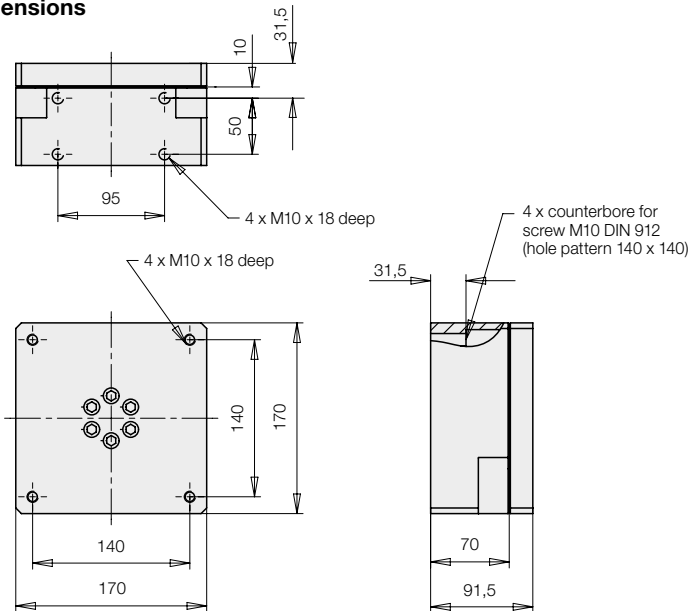

Accessories

• **Adaptor plate**
for vertical mounting of the rotating module
Part-no. 6311-326
See data sheet M 8.110

• **Flange plate**
round for individual fixing holes
Part-no. 6311-400
See data sheet M 8.120

Important notes!

The fixing screws M10 are not included in our delivery.
The rotating module is designed for applications within closed rooms.

Maximum admissible forces:

$F_x = \pm 2,000 \text{ N}$
 $F_y = \pm 2,000 \text{ N}$
 $F_z = \pm 1,000 \text{ N}$

Maximum admissible torques

Total $M_{x/y} = 800 \text{ Nm}$
 M_z : only relevant for version with indexing
(see page 3 to 6)

In the case of eccentric loads, it is recommended to compensate these by counterweights. In off-position the indicated maximum torques may occur.

The forces and torques have to be considered by the operator. During the rotating motion only 50% of the maximum values are admitted.

Automatic indexing operation with hand lever



Description

The rotating module - horizontal axis DMH 200 with automatic indexing is a compact and functional unit.

Rotating as well as indexing are ergonomically operated by one hand lever only.

Operation

To rotate the component part the hand lever is operated in any direction.

Every 90° indexing of the position is made automatically. Engagement and disengagement of the indexing is also effected automatically.

The off-position of the hand lever can be engaged in steps of 90°, so that for every rotation the desired off-position can be adjusted.

The standard indexing and engagement positions of the hand lever are set to 4 x 90°.



Part-no.

6505-01-36-M

Technical characteristics

| | |
|------------------------|-----------------------------|
| Operation: | with hand lever |
| Angle of rotation: | 360° |
| Direction of rotation: | both directions |
| Indexing: | mechanical, automatic |
| | Operation with hand lever |
| | Indexing positions 4 x 90° |
| | Positioning precision < ±1° |
| Weight: | 19 kg |

Maximum admissible load

According to the version without indexing (see page 2).

Maximum admissible torque around the rotation axis M_z

The maximum torque around the rotation axis of the rotating module M_z in engaged mode is **250 Nm**.

The maximum torque to rotate the workpiece must not exceed **15 Nm**.

The module may only be moved in a controlled way to the indexing positions. If the indexing bolt engages in full motion, the module will be dynamically overloaded.

Dimensions

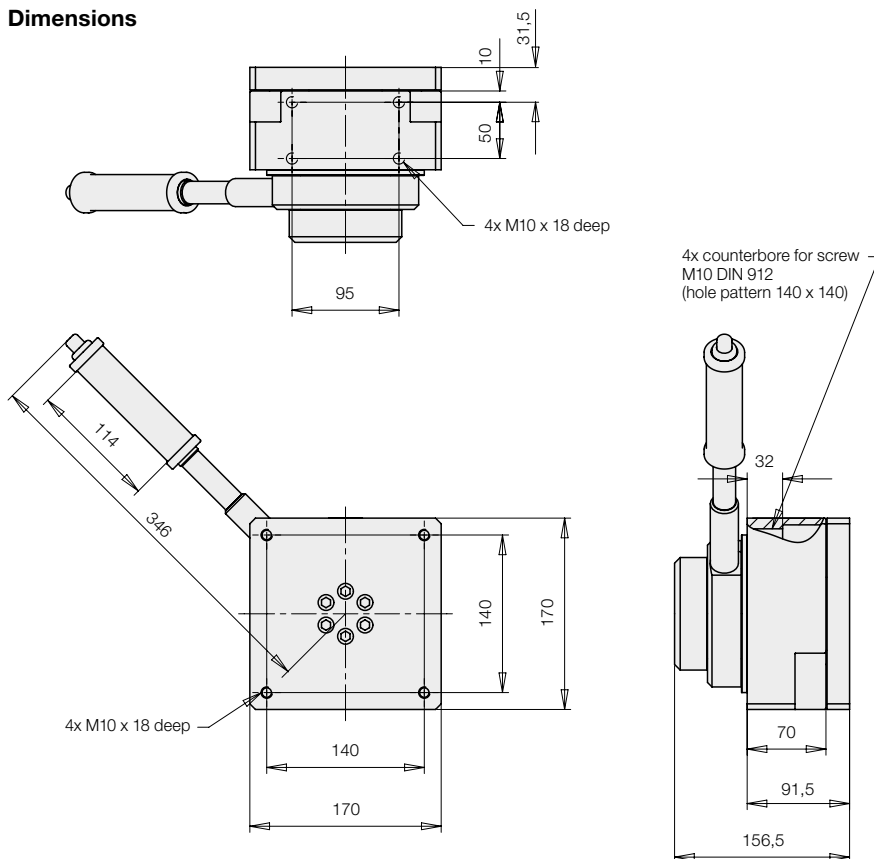

Accessories

• Adaptor plate

for vertical mounting of the rotating module of the rotating module

Part-no. 6311-326

See data sheet M 8.110

• Flange plate

round for individual fixing holes

Part-no. 6311-400

See data sheet M 8.120

Important notes!

In case of vertical mounting of the rotating module - for example on a lifting module - it has to be considered that the hand lever can only be rotated by max. 270° in such applications.

The fixing screws M10 are not included in our delivery. (Recommended property class 10.9)

The rotating module is designed for applications within closed rooms.

Application example



Rotating module DMH 200, with adaptor plate vertically mounted on a lifting module.

Actively operated indexing operation with hand lever



Description

The rotating module - horizontal axis DMH 200 with actively operated indexing is a compact and functional unit. Rotating as well as indexing are ergonomically operated by one hand lever only.

Operation

To unlock the indexing position the hand lever has to be tilted in axial direction by approx. 10° to get connected by form fit with the rotating module.

The component part can only be rotated in any direction by means of the hand lever. Only after safe locking in the desired position the hand lever is free again and the workpiece locked with the housing by form fit.

The off-position of the hand lever can be engaged in steps of 90°, so that for every rotation the desired off-position can be adjusted.

The standard indexing and engagement positions of the hand lever are set to 4 x 90°.

Part-no.

6505-02-36-M

Technical characteristics

| | |
|------------------------|---|
| Operation: | with hand lever |
| Angle of rotation: | 360° |
| Direction of rotation: | both directions |
| Indexing: | mechanical, actively operated with hand lever |
| | Indexing positions 4 x 90° |
| | Positioning precision $\lt; \pm 1^\circ$ |
| Weight: | 19 kg |

Maximum admissible load

According to the version without indexing (see page 2)

Maximum admissible torque around the rotation axis M_z

The maximum torque around the rotation axis of the rotating module M_z in engaged mode is **500 Nm**.

The maximum torque to rotate the workpiece must not exceed **20 Nm** due to ergonomic reasons.

The module may only be moved in a controlled way to the indexing positions. If the indexing bolt engages in full motion, the module will be dynamically overloaded.

Accessories

- Adaptor plate for vertical mounting of the rotating module of the rotating module

Part-no. 6311-326

See data sheet M 8.110

• Flange plate

round for individual fixing holes

Part-no. 6311-400

See data sheet M 8.120

Important notes!

In case of vertical mounting of the rotating module - for example on a lifting module - it has to be considered that the hand lever can only be rotated by max. 270° in such applications. The fixing screws M10 are not included in our delivery (recommended property class 10.9). The rotating module is designed for applications within closed rooms.

Dimensions

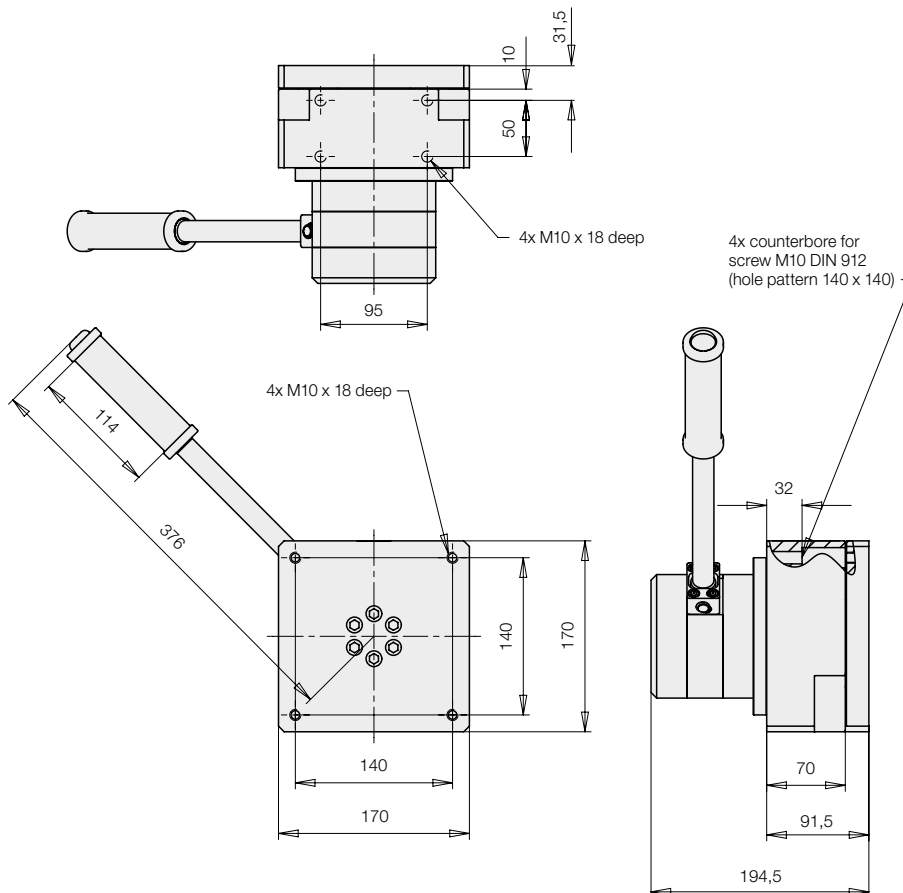

Indexing with foot pedal manual operation

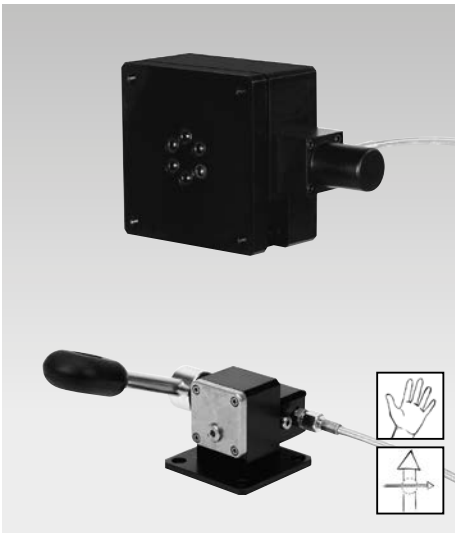

Description

The rotating module - vertical axis DMH 200 with indexing with foot pedal is a compact and functional unit.

It consists of a basic module with integrated indexing mechanism and an operating unit with foot pedal, connected by a 2 m long hydraulic hose.

This flexible connection allows the individual placement of the operating unit at the most favourable ergonomic position.

The rotating operation is manually effected at the workpiece or at the assembly fixture.

Operation of the indexing

By operating the foot pedal by 35° downwards the index is released and the workpiece or the fixture can be rotated.

If the foot pedal is not operated, the index bolt engages automatically into the next indexing position.

The operation with a foot pedal guarantees that the operator always has both hands free.

The standard indexing positions are set to 8 x 45°, 6 x 60°, 4 x 90° and 3 x 120°. Other angles are available on request.

Code for part numbers

Part-no.: 6508-02-XX-O-I

Engagement position

45 = 8 x 45°

60 = 6 x 60°

36 = 4 x 90°

12 = 3 x 120°

Technical characteristics

| | |
|------------------------|------------------------------|
| Operation: | manual at the component part |
| Angle of rotation: | 360° |
| Direction of rotation: | both directions |
| Indexing: | hydromechanical |
| | Operation with foot pedal |
| Weight: | 25 kg |

Maximum admissible load

According to the version without indexing (see page 2)

Maximum admissible torque around the rotation axis M_z

The maximum torque around the rotation axis of the rotating module M_z in engaged mode is **800 Nm**.

In the case of eccentric loads, it is recommended to compensate these by counterweights. In off-position the indicated maximum torques may occur.

The forces and torques have to be considered by the operator. During the rotating motion only 50% of the maximum values are admitted.

Accessories

• Adaptor plate

for vertical mounting of the rotating module

Part-no. 6311-326

See data sheet M 8.110

• Flange plate

round for individual fixing holes

Part-no. 6311-400

See data sheet M 8.120

Delivery

The rotating module and the indexing unit including hydraulic hose and hydraulic oil are delivered as completely assembled unit ready for use.

Dimensions

