

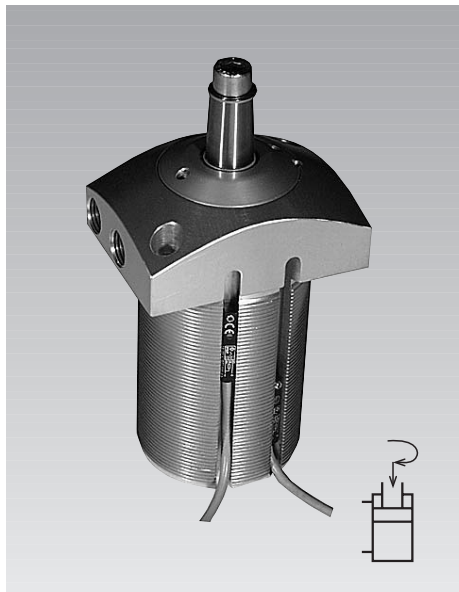

**Pneumatic Swing Clamp**  
top flange-type, for adjustable magnetic sensors  
double acting, max. operating pressure 7 bar

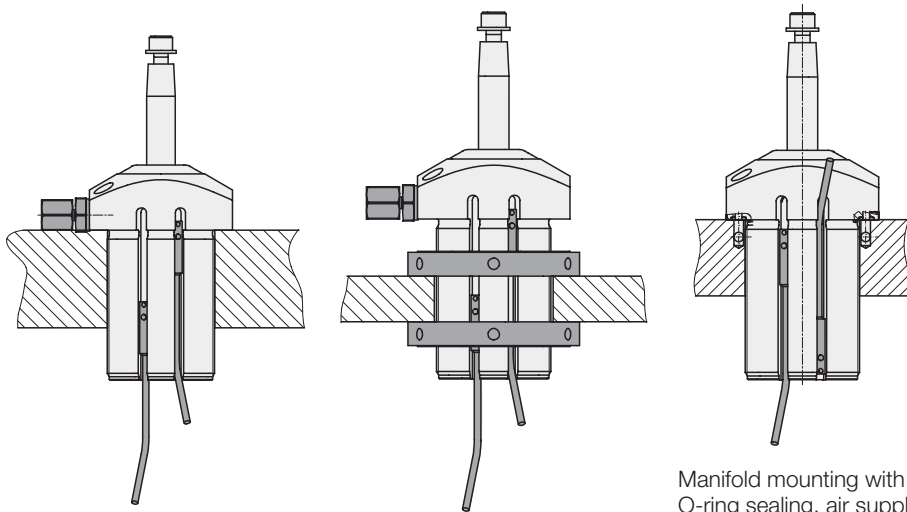

**Installation examples**



Connecting thread, mounted with socket head cap screw

Connecting thread, height adjustment by collar nuts

Manifold mounting with O-ring sealing, air supply through drilled channels in the fixture plate

**Application**

Pneumatic swing clamps are used for applications which require only low clamping forces. The installed magnetic piston allows monitoring of clamping and unclamping position.

**Description**

When pressurising the element, the clamping arm swings and lowers by 90° to the clamping position and then lowers to the clamping point. The position monitoring gives the required information regarding the position of the piston, but not regarding the position of the clamping arm. Monitoring is made by electronic sensors (see accessory) which detect the magnetic field of the magnetic piston. The switching points can be continuously adjusted by displacement of the magnetic sensors.

**Special features**

When adjusting the clamping screw it has to be considered that for the swing motion a part of the total stroke is required. Make sure that the swing motion can be effected without any interference. When using special clamping arms with other lengths, the corresponding operating pressures as shown in the clamping force diagram must not be exceeded.

**Installation**

On fixtures flange-type swing clamps or threaded versions with corresponding collar nuts can be easily adjusted to different workpiece heights.

**Material**

The swing clamps are supplied in corrosion resistant quality. Guide bushing, housing and piston are made of hardcoated aluminium. The piston rod is made of corrosion resistant steel.

**Important notes**

Operating of these pneumatic elements has to be effected with an additional service unit in order to guarantee that the clamping elements are supplied with correctly prepared compressed air.

Operating conditions, tolerances and other data see data sheet A 0.100.

**Advantages**

- Low built-in design possible
- Height adjustment by threaded body and collar nut
- Flange mounting by socket head cap screws
- 5 standard sizes are available
- optionally with thread connection or for manifold mounting with O-ring sealing

**Versions**

- Threaded body for height adjustment
- Manifold mounting with O-ring sealing

**Pneumatic accessories**

see data sheet J 7.400.

**Connecting example**

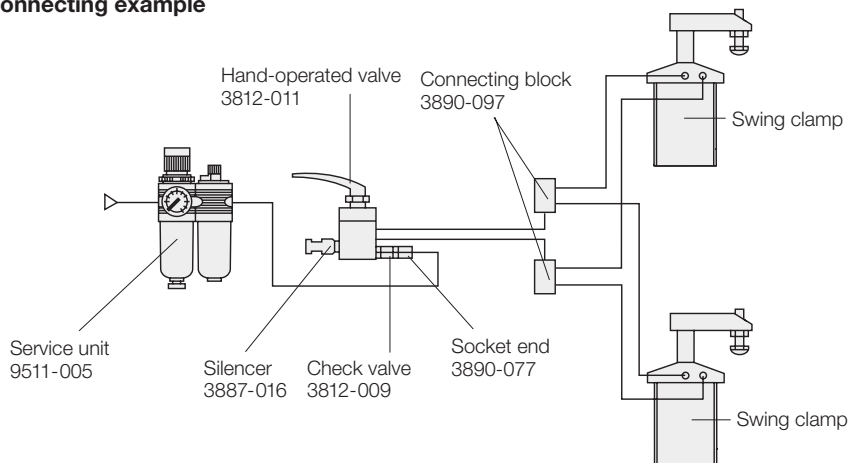

# Threaded body

## Technical characteristics • Accessories

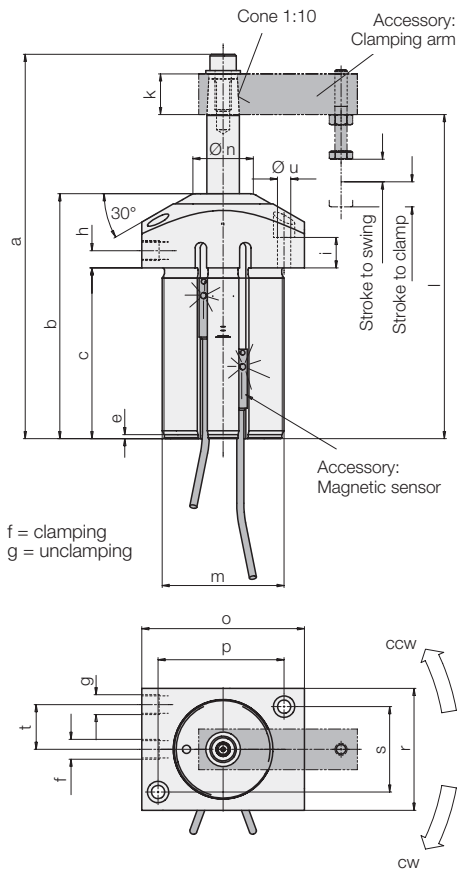

Piston Ø	[mm]	20	32	40	50	63
Piston rod Ø	[mm]	8	12	16	20	25
Stroke to swing	[mm]	7.5	9.5	17	18	23
Stroke to clamp	[mm]	7	9	15	15	18
Force to pull at	[N]	105.5	276.4	422.2	659.7	1050.5
* air pressure	[N]	131.9	345.5	527.7	824.6	1313.1
5 bar						
6 bar		158.3	414.6	633.3	989.6	1575.8
Min. operating pressure	[bar]	3				
Max. operating pressure	[bar]	7				
Angle of rotation	[°]	90° ± 2°				
Weight	[kg]	0.3	0.6	1.0	1.5	2.6
a	[mm]	120	143	189	202	239.5
b	[mm]	76	94.5	120.5	130	150
c	[mm]	48	61	84	85	91
e	[mm]	2	2	2	2	2
f	[mm]	M5	M5	G 1/8	G 1/8	G 1/4
g	[mm]	M5	M5	G 1/8	G 1/8	G 1/4
h	[mm]	6	6.5	8.5	10	13
i	[mm]	7.5	11	15	19	27
□ k	[mm]	12	16	20	25	30
l	[mm]	103.5	119.5	159	164	197
m	[mm]	M40x1.5	M52x1.5	M60x1.5	M70x1.5	M85x2
Ø n	[mm]	14	24	30	38	42
o	[mm]	60	68	80	90	106
p	[mm]	44	54	62	72	86
r	[mm]	40	52	60	70	85
s	[mm]	25	36	42	48	66
t	[mm]	12.8	15	22	23	30.3
Ø u	[mm]	5.5	6.5	6.5	8.5	8.5
Direction of rotation cw	Part-no.	<b>1873-103</b>	<b>1874-103</b>	<b>1875-103</b>	<b>1876-103</b>	<b>1877-103</b>
Direction of rotation ccw	Part-no.	<b>1873-203</b>	<b>1874-203</b>	<b>1875-203</b>	<b>1876-203</b>	<b>1877-203</b>

\* Effective clamping force see diagram (page 3)

### Seat of clamping arm

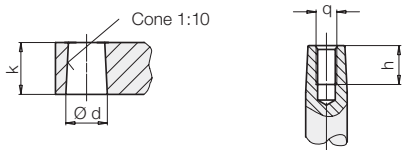

Swing clamp	Ø d + 0,05	□ k	h	q
<b>1873-X03/ -X05</b>	7.85	12	9	M 4
<b>1874-X03/ -X05</b>	11.85	16	15	M 6
<b>1875-X03/ -X05</b>	15.85	20	19	M 8
<b>1876-X03/ -X05</b>	19.85	25	18	M 12
<b>1877-X03/ -X05</b>	24.85	30	25	M 10

### Clamping arm

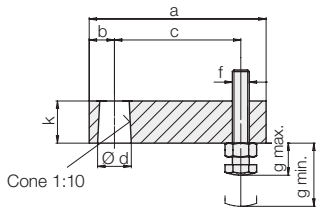

Swing clamp	a	b	c	Ø d + 0,05	f	g min.	g max.	□ k	Part-no.
<b>1873-X03/ -X05</b>	54	7	42	7.85	M 4	8	28	12	<b>0187-326</b>
<b>1874-X03/ -X05</b>	68	10	52	11.85	M 6	12	27	16	<b>0187-426</b>
<b>1875-X03/ -X05</b>	78	12	58	15.85	M 6	12	42	20	<b>0187-526</b>
<b>1876-X03/ -X05</b>	90	14	68	19.85	M 8	15	42	25	<b>0187-626</b>
<b>1877-X03/ -X05</b>	110	18	80	24.85	M 10	19	56	30	<b>0187-726</b>

### Clamping arms for special versions

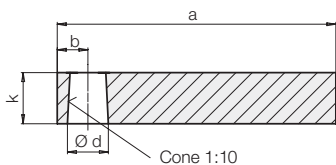

Swing clamp	a	b	Ø d + 0,05	□ k	Part-no.
<b>1873-X03/ -X05</b>	62	7	7.85	12	<b>3548-355</b>
<b>1874-X03/ -X05</b>	72	10	11.85	16	<b>3548-356</b>
<b>1875-X03/ -X05</b>	95	12	15.85	20	<b>3548-357</b>
<b>1876-X03/ -X05</b>	116	14	19.85	25	<b>3548-353</b>
<b>1877-X03/ -X05</b>	143	18	24.85	30	<b>3548-358</b>

### Contact bolts, dome head

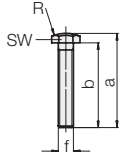

Swing clamp	a	b	f	R	SW	Part-no.
<b>1873-X03/ -X05</b>	32.5	30	M 4	15	7	<b>3614-141</b>
<b>1874-X03/ -X05</b>	33.5	30	M 6	20	10	<b>3614-137</b>
<b>1875-X03/ -X05</b>	48.5	45	M 6	20	10	<b>3614-138</b>
<b>1876-X03/ -X05</b>	50	45	M 8	20	13	<b>3614-139</b>
<b>1877-X03/ -X05</b>	66.5	60	M 10	35	17	<b>3614-140</b>

### Flange nut

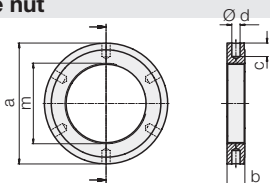

Swing clamp	Ø a	b	c	Ø d	m	Part-no.
<b>1873-X03</b>	62	12	8	4x6	M 40x1.5	<b>3527-040</b>
<b>1874-X03</b>	80	13	10	6x6	M 52x1.5	<b>3527-082</b>
<b>1875-X03</b>	90	13	10	6x6	M 60x1.5	<b>3527-042</b>
<b>1876-X03</b>	100	14	12	6x8	M 70x1.5	<b>3527-083</b>
<b>1877-X03</b>	120	16	12	6x8	M 85x2.0	<b>3527-084</b>

# Manifold mounting with O-ring sealing

## Technical characteristics

### Effective clamping force

**1873-X03**  
**1873-X05** Max. clamping arm length s [mm]  
 98 72 58 48 42

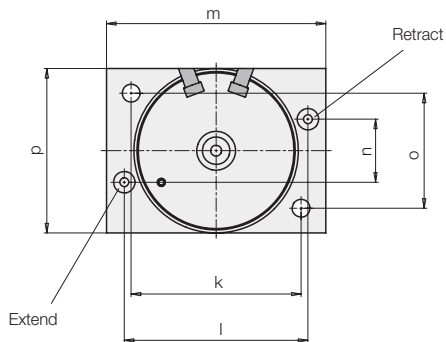
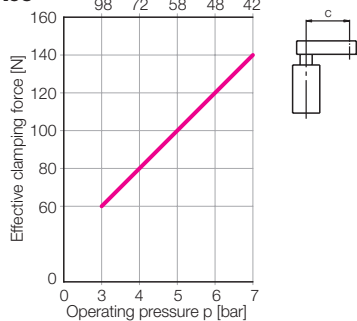

**1874-X03**  
**1874-X05** Max. clamping arm length s [mm]  
 120 90 72 60 52

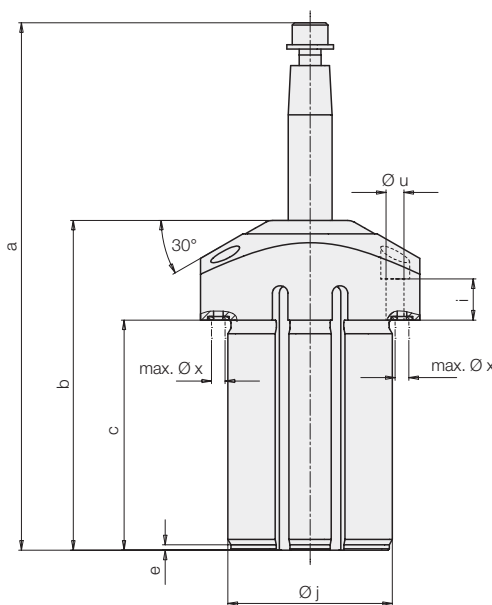
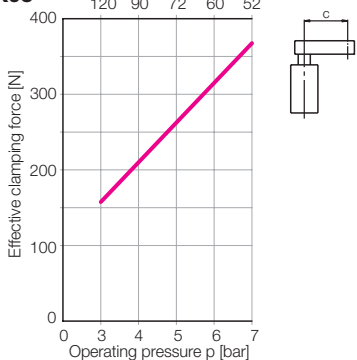

**1875-X03**  
**1875-X05** Max. clamping arm length s [mm]  
 134 100 80 68 58

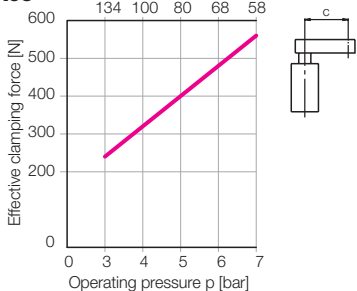

**1876-X03**  
**1876-X05** Max. clamping arm length s [mm]  
 158 120 95 78 68

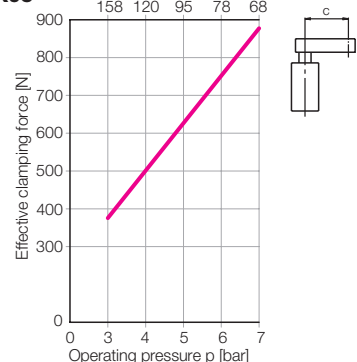

**1877-X03**  
**1877-X05** Max. clamping arm length s [mm]  
 186 140 112 92 80

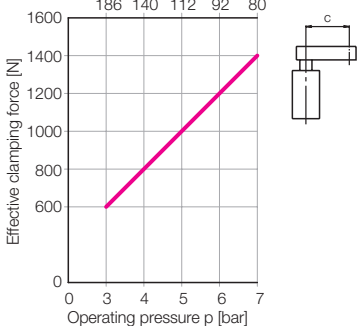

### Clamping force

		<b>1873-105</b>	<b>1874-105</b>	<b>1875-105</b>	<b>1876-105</b>	<b>1877-105</b>
		<b>1873-205</b>	<b>1874-205</b>	<b>1875-205</b>	<b>1876-205</b>	<b>1877-205</b>
Piston Ø	[mm]	20	32	40	50	63
Piston rod Ø	[mm]	8	12	16	20	25
a	[mm]	120	143	189	202	239.5
b	[mm]	76	94.5	120.5	130	150
c	[mm]	48	61	84	85	91
e	[mm]	2	2	2	2	2
i	[mm]	7.5	11	15	19	27
Ø j	[mm]	40	52	60	70	85
k	[mm]	44	54	62	72	86
l	[mm]	47	56	67	76	90
m	[mm]	60	68	80	90	106
n	[mm]	18	27	23	36	40
o	[mm]	25	36	42	48	66
p	[mm]	40	52	60	70	85
Ø u	[mm]	5.5	6.5	6.5	8.5	8.5
max. Ø x	[mm]	3.5	3.5	3.5	5	5
Dimensions O-ring		4.47x1.78	4.47x1.78	4.47x1.78	7x1.5	7x1.5
<b>Part-no. spare O-ring</b>		<b>3000-968</b>	<b>3000-968</b>	<b>3000-968</b>	<b>3000-342</b>	<b>3000-342</b>

O-rings are included in delivery. Other dimensions see page 2.

## Accessory: Magnetic sensors

Compared with traditional reed switches the electronic magnetic sensors offer the following advantages:

- Indifference to shock and vibration
- Bounce-free output signal
- Only one switching point
- Wear resistant
- Protection against reverse battery
- Protected against short circuits

Electric connection is made as per traditional inductive proximity switches; up to four magnetic sensors can be connected in series.

### Important notes

Steel can influence the magnetic field of the magnetic piston and thereby the position of the switching point. If the pneumatic swing clamp is flange mounted on a steel plate, the sensor has to be adjusted by displacement in the mounted condition. If the magnetic sensor is outside of a protecting bore hole and is exposed to changing influences of adjacent steel parts, e.g. swarf, protection for 30 mm has to be provided.

### Electronic magnetic sensor

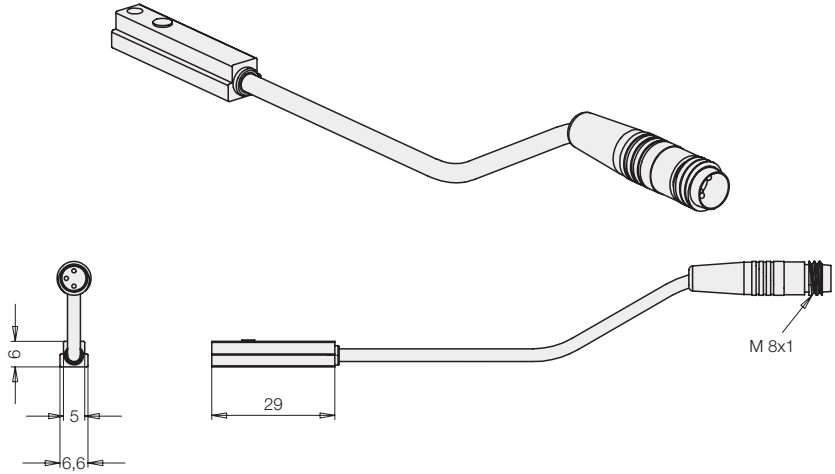

### Connecting cable with coupling

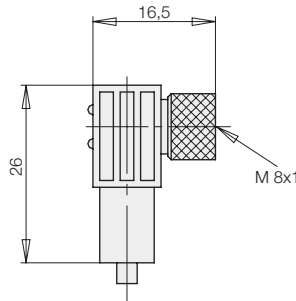

### Connecting scheme

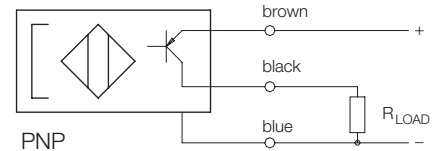

### Technical characteristics

	Electronic magnetic sensor	Connecting cable with coupling
Cylinder body material	PA 6	
Voltage	10 – 30 V DC	10 – 30 V DC
Residual ripple	max. 10%	
Current load $I_{LOAD}$	200 mA	
Current consumption	≤ 25 mA	
Protected against short circuits	yes	
Protection against reverse battery	installed	
Switching hysteresis	typ. 1.5 mm	
Protection as per IEC 529	IP 65	IP 67
Environmental temperature	-25°C up to +70°C	-25°C up to +90°C
Plug connection	M8 plug	M8 coupling
Function display	LED (yellow)	LED (yellow)
Voltage	no	LED (green)
Cable, length of cable	0.26 m	PUR, 5 m
Output	npn	
<b>Part-no. (1 off)</b>	<b>3829-147</b>	<b>3829-099</b>

### Further accessories

see data sheet B 1.555

- Pin-and-socket connector
- Y-distributor
- Reversing plug
- Voltage regulator