

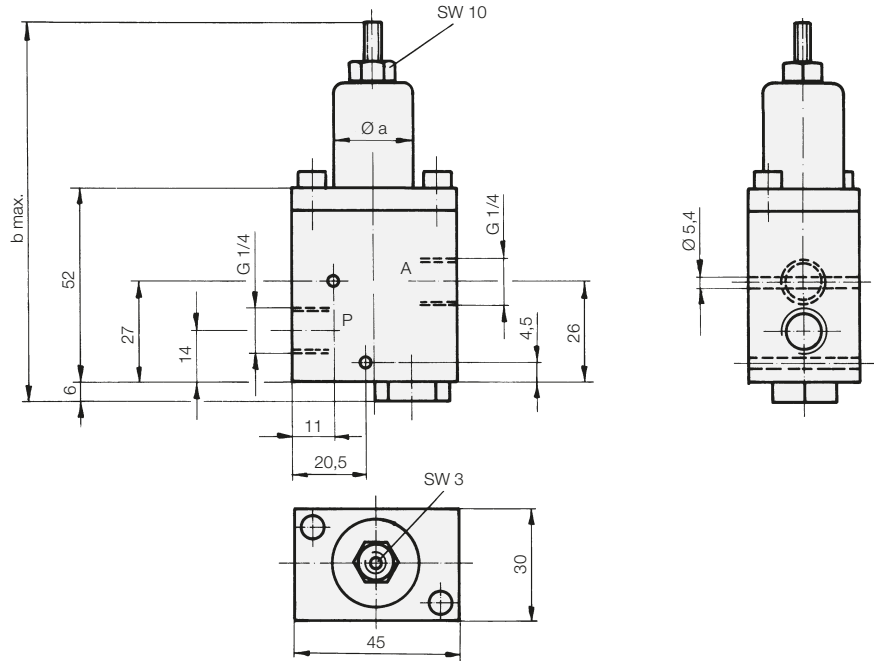

**Sequence Valve ND 4**  
with check valve  
max. operating pressure 500 bar

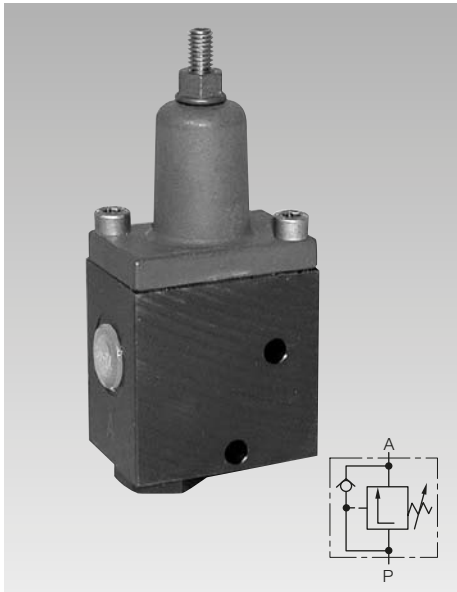

**Description**

Sequence valves are used in power workholding circuits for pressure dependent sequence control. The compact size allows mounting directly to the clamping fixture, requiring only one pressure line from the power unit to the fixture for single-acting cylinders.

**Valve combination see back of the page**

Several sequence valves can be manifold mounted together to form a battery with only one common P-line.

Type	directly-controlled spool valve		
Type of mounting	pipes or screws M 5		
Port size	G 1/4	G 1/4	G 1/4
Max. operating pressure [bar]	500	500	500
Max. flow rate [l/min]	8	8	8
Range of adjustment [bar]	10 – 75	10 – 150	100 – 450
Pressure change per rotation [bar]	approx. 6.5	approx. 15	approx. 30
Check valve opening pressure [bar]	0.15	0.15	0.15
Ø a [mm]	22	22	28
b max. [mm]	108.5	108.5	145
Weight [kg]	0.52	0.52	0.64
<b>Part no.</b>	<b>2954-410</b>	<b>2954-420</b>	<b>2954-440</b>

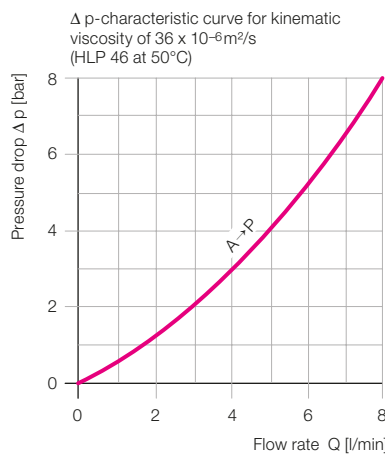

**Application example**

The workpiece is to be positioned and clamped in the fixture with hydraulic clamping cylinders.

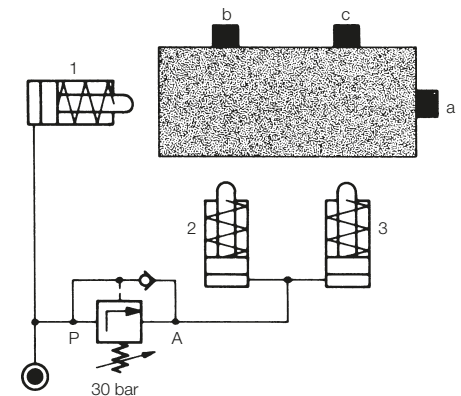

**Clamping sequence**

1. Cylinder 1 pushes workpiece against stop a.
2. Pressure rises to 30 bar, sequence valve opens.
3. Cylinder 2 and 3 extend and push the workpiece against stop b and c.
4. Oil pressure rises uniformly in all cylinders, because of the throttle-free passage of the opened sequence valve.

## Sequence valves for manifold mounting

These sequence valves are also available for manifold mounting. Hydraulic oil is supplied and returned through drilled channels in the fixture body.

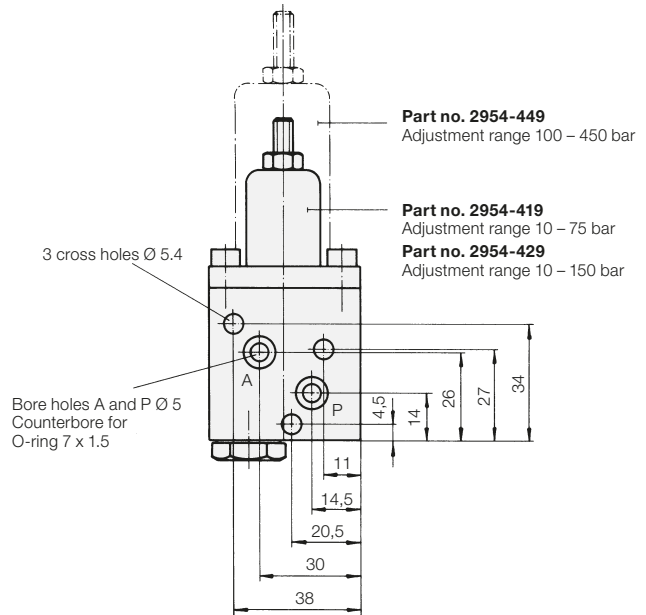
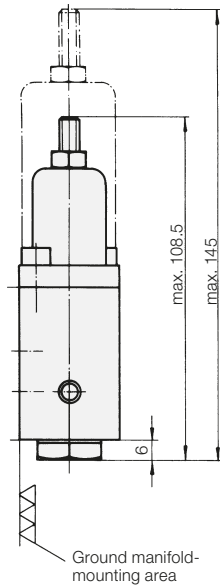
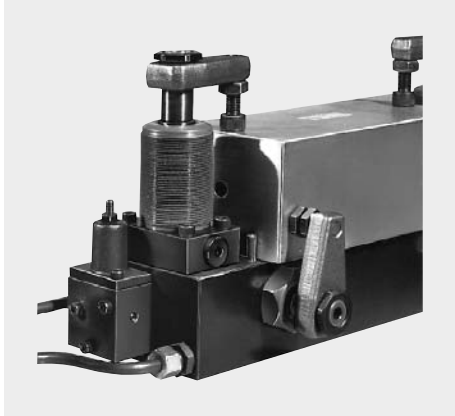

Range of adjustment [bar]	Part no.
10 – 75	<b>2954-419</b>
10 – 150	<b>2954-429</b>
100 – 450	<b>2954-449</b>
Spare O-ring	<b>3000-342</b>

## Sequence valve battery combination

These batteries consist of one input valve and up to five series valves. Only one pressure line is required to port P of the input valve.

The other valves are interconnected by an internal passage, sealed with an O-ring between each valve.

To assure optimum operation it is required to adjust settings between adjacent valves of the type 2954-42X not below a pressure differential of 25 bar, and for the type 2954-44X not below 50 bar.

Description	Range of adjustment [bar]	Part no.
Input valve	10 – 150	<b>2954-427</b>
Input valve	100 – 450	<b>2954-441</b>
Series valve	10 – 150	<b>2954-428</b>
Series valve	100 – 450	<b>2954-442</b>

Description	Number of valves	Dimensions	Part no.
Tie rod	2	M 5 x 72	<b>3619-029</b>
Tie rod	3	M 5 x 102	<b>3619-031</b>
Tie rod	4	M 5 x 132	<b>3619-032</b>
Tie rod	5	M 5 x 162	<b>3619-033</b>
Tie rod	6	M 5 x 192	<b>3619-034</b>

## Example of ordering

Battery combination consisting of 3 valves with an adjustment range of 10–150 bar and 1 valve with an adjustment range of 100–450 bar.

	Bestell-Nr.
1 off input valve	<b>2954-427</b>
2 off series valve	<b>2954-428</b>
1 off series valve	<b>2954-442</b>
2 off tie rod M 5 x 132	<b>3619-032</b>
Spare O-ring	<b>3000-343</b>

Required plugs, O-rings and hexagon nuts are included.

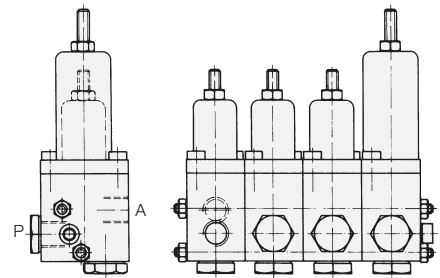

## Hydraulic circuit diagram

Sequence control for 5 single-acting clamping cylinders.

