



Workholding Systems MC-P Z, Concentric Clamping mechanically or hydraulically operated, jaw widths 40, 60, 100 and 125 mm



Advantages

- Patented segment design
- Compact design
- High precision and accuracy of the manufactured workpieces by high rigidity
- High zero-point stability
- Sturdy design and good swarf protection
- Large jaw openings
- Extensive range of jaws
- Clamping of raw and finished parts without retrofitting
- Easy to maintain

Description

Workholding systems of the MC-P Z series excel by a very compact design and their patented segment design.

Thanks to the adjusting spindle arranged in the upper part of the housing, deformation in the base during clamping is reduced to a minimum. Thus, a high rigidity of the workholding system is obtained.

The patented segment design ensures a high degree of precision and stability. The guiding clearance is reduced to nearly zero. All essential components are made of hardened steel.

The workholding systems MC-P 100 Z / 125 Z are already prepared for the use on zero point clamping systems. For this purpose, there are location threads for retractable nipples at the bottom side of the housing.

For workholding systems MC-P Z a wide range of clamping jaws is available (see data sheet WS 5.450-Z).

Customised versions

MC-P workholding systems can also be delivered as customised versions. For example with other lengths, height or with individual mounting holes.

Please contact us.

Consultation

Our experts will be pleased to advise you also on site, and work with you to find the optimum clamping solution.

Extensive information such as drawings and CAD models are available on request.

Technical data

Clamping principle: **concentric clamping mechanically**
 Operation: **mechanically** with a torque wrench
hydraulically with a power unit

MC-P 40 Z

Jaw width: 40 mm
 Clamping force: 7.5 kN at 23 Nm
 Clamping stroke: 20 mm
 Max. jaw opening: 6–79 mm

MC-P 60 Z and ZH

Jaw width: 60 mm
 Clamping force: 15 kN at 50 Nm/320 bar
 Clamping stroke: 30 mm
 Max. jaw opening: 6–150 mm

MC-P 100 Z and ZH

Jaw width: 100 mm
 Mechanical clamping force: 25 kN at 80 Nm
 Hydraulic clamping force: 20 kN at 200 bar
 Clamping stroke: 50 mm
 Max. jaw opening: 6–204 mm

MC-P 125 Z and ZH

Jaw width: 125 mm
 Clamping force: 35 kN at 200 Nm/240 bar
 Clamping stroke: 101 mm
 Max. jaw opening: 6–400 mm

MC-P 125 Z Compact

Jaw width: 125 mm
 Clamping force: 35 kN at 200 Nm
 Clamping stroke: 10 kN
 max. jaw opening: 6–215 mm

Versions

MC-P Z mechanically operated

In the mechanically-operated version, the clamping force is built up with a threaded spindle. When operating, both clamping slides move mechanically linked to the centre of the clamping system.

A torque wrench is used for exact and reproducible clamping force adjustment.

MC-P ZH hydraulically operated

In the hydraulically-operated version, the clamping force is built up by an externally generated hydraulic pressure. When pressurising, both clamping slides move mechanically linked to the centre of the clamping system. During unclamping, the clamping slides return hydraulically to the position that had been set with adjusting screws for stroke limitation. Thus, a further unnecessary wide opening of the clamping system is avoided.

The clamping force adjustment is made by the setting of the operating pressure.

Application

The workholding systems MC-P Z are especially advantageous for 5-axis machining. The compact design allows a good accessibility of the tools to the workpiece. Collision-free tool paths and a 5-sided workpiece machining can be achieved with short standard tools.

Due to the good swarf protection, workholding systems MC-P Z are particularly suitable for the use in pallet systems.

The high force and stability obviate the need for pre-stamping of the workpieces.

Accessories

- Clamping jaws and jaw inserts, accessories for mounting, positioning and operation see data sheet WS 5.450-Z
- Rapid change block Quintus see data sheet WS 5.6150
- Hydraulic pressure generators on request

Application example

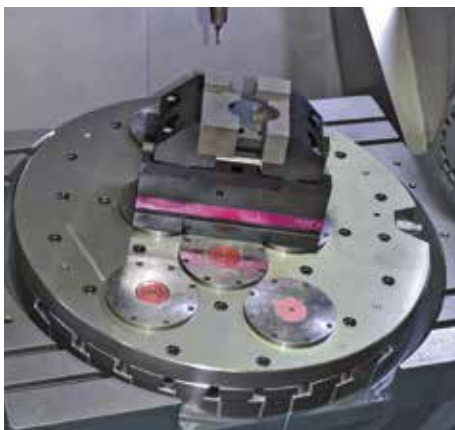

Workholding system MC-P Z with workpiece-specific base jaw and form jaw used on a 5-axis machining centre.

Technical data • Dimensions
mechanically operated • jaw widths 40, 60 and 100 mm

MC-P 40 Z

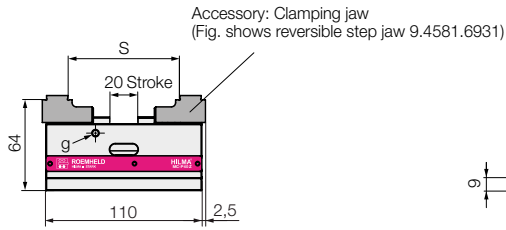

View from below

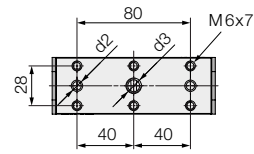

MC-P 60 Z

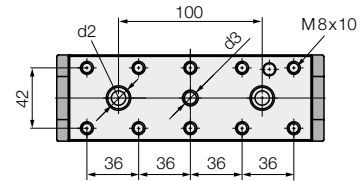
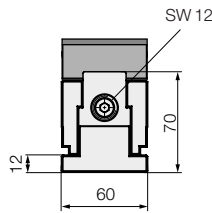
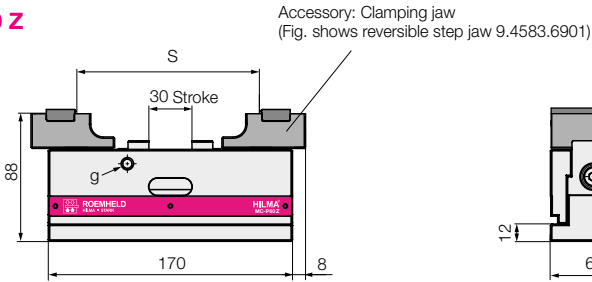

MC-P 100 Z

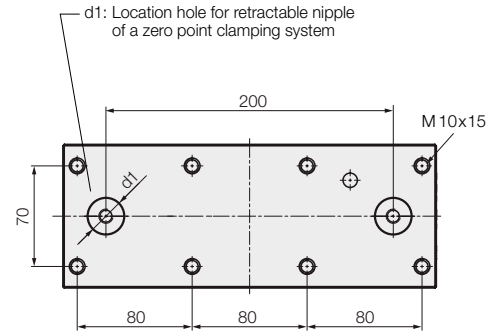
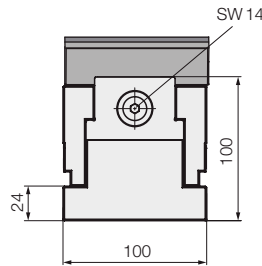
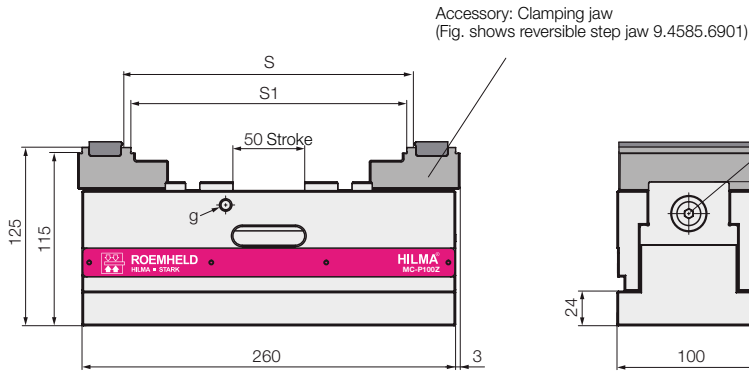

All dimensions in [mm]

Type		MC-P 40 Z	MC-P 60 Z	MC-P 100 Z
Clamping principle		concentric	concentric	concentric
Operation		mechanical	mechanical	mechanical
Clamping force / torque	[kN/Nm]	7.5/23	15/50	25/80
S*	[mm]	6 – 79	6–150	18–204
S1*	[mm]	–	–	6–192
d1	[mm]	–	–	25+0.01x5 / M10x14
d2	[mm]	6F7	10F7	–
d3	[mm]	M10x12	M10x11	–
g on both sides	[mm]	M5x6	M8x10	M8x14
Weight without clamping jaws	[kg]	1.5	4.7	17.7
Part no. without clamping jaws		9.4581.0301	9.4583.0301	9.4585.0301

* depending on the used clamping jaw

Technical data • Dimensions
mechanically operated • jaw width 125 mm

MC-P 125 Z

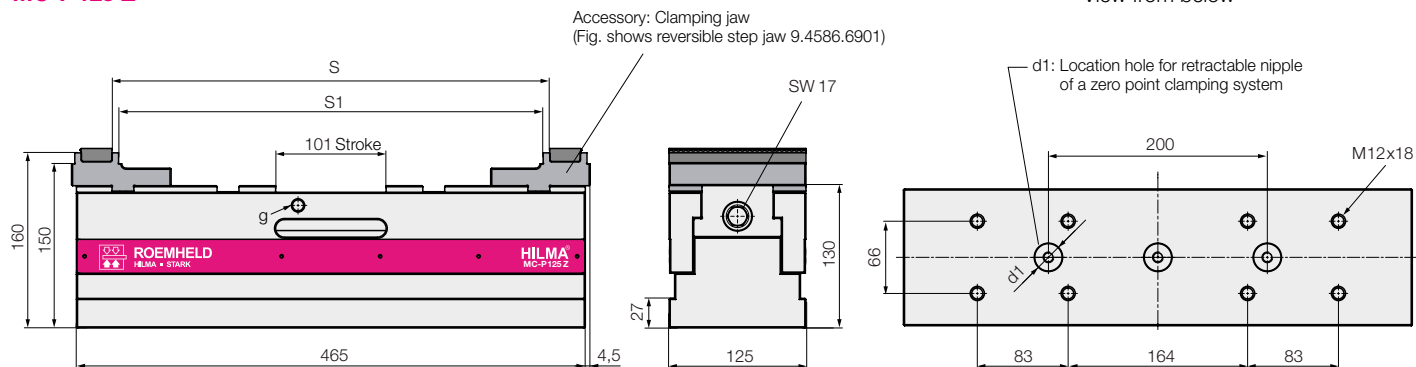

MC-P 125 Z Compact

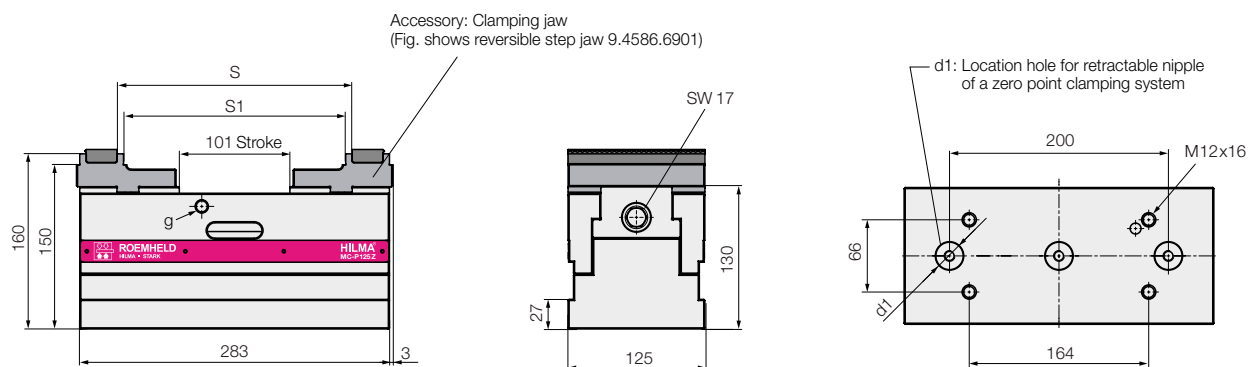

All dimensions in [mm]

Type		MC-P 125 Z	MC-P 125 Z Compact
Clamping principle		concentric	concentric
Operation		mechanical	mechanical
Clamping force/torque	[kN]	35/200	35/200
S*	[mm]	18–400	18–215
S1*	[mm]	6–388	6–203
d1	[mm]	25+0.01x5/M10x18	25+0.01x5/M10x18
g on both sides	[bar]	M12x18	M12x18
Weight without clamping jaws	[kg]	52.3	30.5
Part no. without clamping jaws		9.4586.0301	9.4586.0601

* depending on the used clamping jaw

Technical data • Dimensions

hydraulically operated • jaw widths 60, 100 and 125 mm

MC-P60 ZH

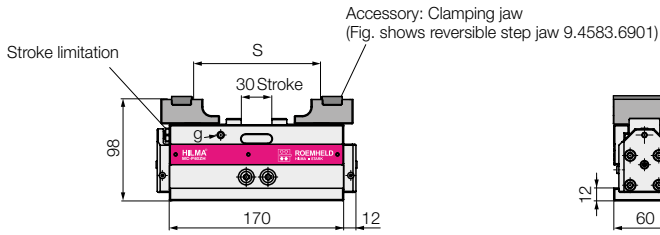

View from below

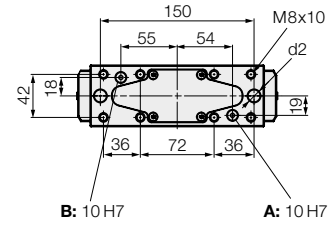

A: Clamping
B: Unclamping

MC-P100 ZH

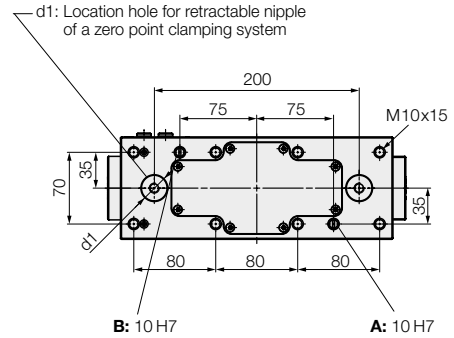
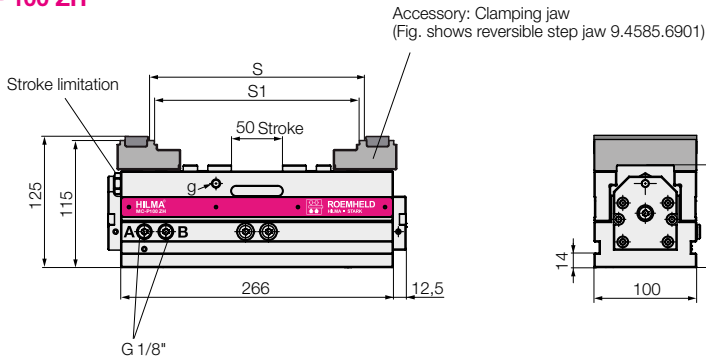

MC-P125 ZH

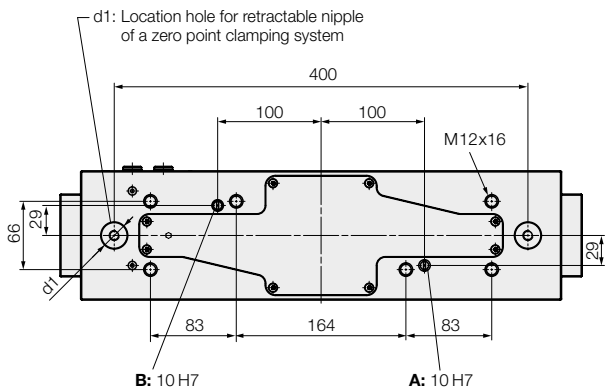
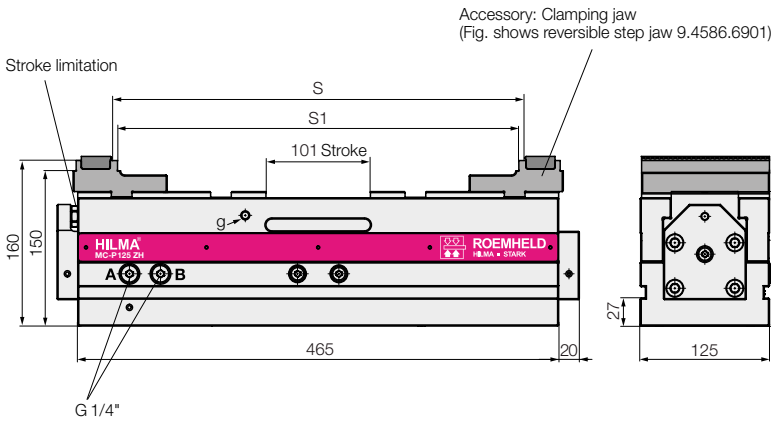

All dimensions in [mm]

Type		MC-P60 ZH	MC-P100 ZH	MC-P125 ZH
Clamping principle		concentric	concentric	concentric
Operation		hydraulic	hydraulic	hydraulic
Clamping force / operating pressure	[kN/bar]	15/320	20/200	35/240
S*	[mm]	6–150	18–204	18–400
S1*	[mm]	–	6–192	6–388
d1	[mm]	–	25+0.01x5 / M10x14	25+0.01x5 / M10x14
d2	[mm]	12F7	–	–
g on both sides	[mm]	M6x7	M8x11	M8x11
Min. operating pressure	[bar]	50	50	50
Max. operating pressure	clamping [bar]	320	200	240
Operating pressure	unclamping [bar]	50	50	50
Oil volume per 1 mm stroke	[cm ³]	0.5	1	1.6
Weight without clamping jaws	[kg]	5.4	17.4	50.5
Part no. without clamping jaws		9.4583.0401	9.4585.0401	9.4586.0401

* depending on the used clamping jaw